



HiMoldeMaster

MSc Logistics

The discussion of how can those small-medium sized air cargo service agents to improve their national distribution network

Author(s): Shasha KANG and Zheng ZHANG

Molde, 2008



Student Assignment for the Master Degree

Title: The discussion of how can those small-medium sized air cargo service agents to improve their national distribution network

Author (-s): Shasha KANG an Zheng ZHANG

Subject code: LOG 950

ECTS credits: 30

Year: 2008

Supervisor: Cheng HUANG

Agreement on electronic publication of master thesis

Author(s) have copyright to the thesis, including the exclusive right to publish the document (The Copyright Act §2).

All theses fulfilling the requirements will be registered in BIBSYS Brage, but will only be published (open access) with the approval of the author(s).

Theses with a confidentiality agreement will not be published.

I/we hereby give HiM the right to, free of charge, make the thesis available for publication on the Internet:

yes no

Is there an agreement of confidentiality?

(a supplementary confidentiality agreement must be filled in)

yes no

Can the thesis be published when the period of confidentiality is expired?

yes no

Should the thesis be kept from public access?

(according to the Freedom of Information Act §5a / The Public Administration Act §13)

yes no

Date: 18/6 2008



STANDARD AGREEMENT

This agreement is between Shasha Kang & Zhen Zhang (Student) ^{25.03.1983 & 18.06.1984} (Date of birth),

..... (Faculty Advisor at Molde University College),

Suzhou Dapeng Logistics Co., Ltd. (Company/Institution),
And Molde University College/Office Manager

concerning the use of specifications and results reported in the Master's degree thesis in accordance with the study plan for the Master's degree program in Logistics at Molde University College.

1. The student shall complete the work assigned for the Master's degree thesis at:
Suzhou Dapeng Logistics Co., Ltd. (Company/Institution)

The title of the thesis is: The discussion of how can those small-medium sized air cargo service agents to improve their national distribution network.

2. The student has copyrights to the thesis. Those copies of the thesis submitted for evaluation along with descriptions and models, such as computer software that is included as part of or as an attachment to the thesis, belongs to Molde University College. The thesis and its attachments can be used by the College for teaching and research purposes without charge. The thesis and its attachments must not be used for other purposes.

3. The student has the right to publish the thesis, or parts of it, as an independent study or as part of a larger work, or in popularized form in any publication.

4. The company/institution has the right to receive a copy of the thesis with attachments, and the College's evaluation of it. The company/institution will have three (3) months from the time the thesis is submitted to the College for censoring to determine whether a patent is possible and to apply for a patent for all or part of the results in the thesis. The specifications and results in the thesis can be used by the company/institution in its own activities.

5. A separate confidentiality agreement may be entered into between the parties, if the company/institution so desires.

Place Suzhou

Date 23.04.2008

Shasha Kang, Zhen Zhang
Student

Faculty Advisor

XU WEI
Company/Institution

Office Manager





SUPPLEMENTARY AGREEMENT/CONFIDENTIALITY AGREEMENT

(Supplement to Point 5 of the Standard Agreement)

This agreement is between Shasha Kang & Zhen Zhang (Student) 25.03.1983 & 18.06.1984 (Date of birth),

..... (Faculty Advisor at Molde University College)

Suzhou Dapeng Logistics Co., Ltd. (Company/Institution),

and
Molde University College/Office Manager

This is a supplement to the Standard Agreement, which defines the use of specifications and results reported in a Master's degree thesis in accordance with the study plan for the Master's degree program in Logistics at Molde University College.

1. As stated in Point 5 of the Standard Agreement the parties named above agree to limit access to the Master's degree thesis for 3 years from the date of this agreement.
2. The reason for keeping the thesis results confidential is so that the company/institution can avoid giving away information that would give others a competitive advantage.
3. The thesis must be submitted to Molde University College. It will be kept in a secure room in the main archive at the College during the period agreed upon. The thesis can be borrowed during this period if a written request is submitted and the company/institution gives permission. After this period has ended the thesis will be placed in the library for general use.
4. Four copies of this agreement **must be signed** so that each party will have a copy. The agreement is **valid when it has been approved and signed by the Office Manager at Molde University College.**

City..... Suzhou

Date..... 23.04.2008

Shasha Kang, Zhen Zhang
Student

Faculty Advisor

XU WEI
Company/Institution 205000209981

Agreement approved by:

Office Manager

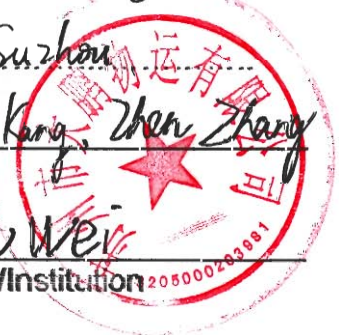



**The discussion of how can those small-medium sized
air cargo service agents to improve their national
distribution network**

by

Shasha KANG (061184)

Zheng ZHANG (061191)

Supervisor: Cheng HUANG

Thesis

Presented to the Faculty of Economics

of the Molde University college

in Partial Fulfillment

of the Requirements

for the Degree of

Master of Science in Logistics

Molde University College at Molde, Norway

May 2008

Preface

This paper is the master thesis of Shasha KANG and Zhen ZHANG, students at Molde University College. This research project is the last part of our study program of Master of Science in Logistics. Our deepest gratitude goes first and foremost to Professor Øyvind Halskau and our supervisor Cheng HUANG, for their constant encouragement and guidance. They have helped us a lot through all the stages of the writing of the thesis, as well as the study period in Molde. It is quite important for us to get the support from them in academic guidance and helpful suggestions throughout our research and writing process. Without their consistent and illuminating instruction, this thesis could not have reached its present form.

Second, we would like to express our heartfelt thanks to Wei XU, the director-general manager of Suzhou Dapeng Logistics Co., Ltd. Without his help, we can hardly finish our research successfully. We would also like to thank the relevant staff working at Dapeng. They are customer service manager Xiaohua YAO, HR manager Hui WANG, IT manager Lei XU, operation manager Chengrao ZHAO and the operator Chunchen DING. All of them have proved more kind supporting from time to time for our information collections. This available information is playing a very important role in making our thesis. We also need to appreciate our friend Teacher Xiangxin YANG who is working at University of Science and Technology of Suzhou and introduced us to do our practice in Dapeng for our thesis.

Furthermore, we are also greatly indebted to our best friend Wen LI who graduated from Cambridge and has stayed in England for seven years. She gave a lot of helps and suggestion for our written English.

Lastly, our thanks would go to our beloved families for their loving considerations and great confidence these years. We also owe our sincere gratitude to our friends who gave us their help during the year we spent in Molde and especially during the difficult

course of the thesis.

Shasha KANG

Zhen ZHANG

©Copyright by Shasha KANG & Zhen ZHANG 2008

All Rights Reserved

Abstract

With the rapid development of the China's economy and commerce, the logistic industry in China has been encouraged to grow and develop very quickly. However, comparing with the more developed countries, the logistic industry in China is still on their early stage, lack of large-scale competitive third-party logistics enterprises, as such small-medium sized logistics companies become very unattractive especially when foreign logistics companies entering into the market. The purpose of this thesis is focusing on the small-medium sized logistic companies' problems due to small-scale, relatively high cost and lack of customers in their air cargo service agent business, take Suzhou Dapeng logistics Co., Ltd as a case study and suggest some feasible solutions such as forming strategic alliance network, improving the original alliance network and enhancing the strategic alliance's core competitiveness. Optimizing the resources allocation through sharing the information system among strategic alliance members, construct more integrated and reliable distribution network nationally to compete with local and foreign large-sized logistic companies.

Key words

Air cargo service agent, TCA, the strategic alliance network, the information platform

Contents

Preface	i
Abstract.....	iii
Contents	iv
List of tables	vi
List of figures	vi
1. Introduction	1
2. Background environment of local small-medium sized air cargo service agents	
business	2
2.1 Potential competitors.....	3
2.2 Current competitors.....	4
2.3 Substitutes	5
2.4 Buyers' market	5
2.5 Suppliers.....	6
3. The introduction of current strategic alliance network I	7
3.1 The SWOT analysis of the strategic alliance network I.....	7
3.1.1 Strengthens	7
3.1.2 Weaknesses.....	8
3.1.3 Opportunities	8
3.1.4 Threats	9
3.2 The analysis of the competitiveness of air cargo service agents	9
3.3 Case study of an air cargo service agent--Dapeng	12
3.3.1 The business process of Dapeng air cargo service agent	13
3.3.2 The present problems of Dapeng.....	14
4. Methodology and literature review	20
4.1 Methodology	20
4.2 The transaction cost analysis.....	20
5. The solutions for the strategic alliance network I and Dapeng	25
5.1 The strategies for the strategic alliance network I.....	25
5.1.1 Relatively dispersive members and lack of solidarity apparently	

(Bounded rationality and opportunism)	25
5.1.2 High operating costs (Information asymmetry)	26
5.1.3 Lack of competitiveness (Small numbers)	27
5.1.4 Low information technology	27
5.2 The feasible solutions for Dapeng.....	28
5.2.1 How to improve the efficiency of information services and automate the settlement process.....	28
5.2.2 How to look on the shrinking profit with increasing sales and lack of high quality of customers	31
5.2.3 The analysis of high fixed cost, low efficiency and no reliable national distribution network	32
5.3 Establishing a new-type strategic alliance network II.....	37
6. The detailed prospect of the strategic alliance network II.....	38
6.1 The brief introduction of the strategic alliance network II.....	38
6.2 The basic framework of the strategic alliance network II	39
6.3 The detailed constructing direction of the strategic alliance network II	42
6.3.1 The construction of the information system.....	42
6.3.2 New standard of the integration for the strategic alliance network II (the new alliance)	45
7. Conclusion: The prospect of optimizing the distribution network management.....	48
8. Further research	49
8.1 Value-added services	50
8.2 Risk limited	51
References	52

List of tables

Table 1: The competitiveness test of an air cargo service agent.....	10
Table 2: The cost composition.....	35
Table 3: The ranking and grading standard	48

List of figures

Figure 1: The process of air cargo business.....	2
Figure 2: The analysis of the five forces	6
Figure 3: The analysis of Dapeng's competitiveness	11
Figure 4: The business process of Dapeng air cargo service agent	13
Figure 5: The example of the shrinking profit with increasing sales	16
Figure 6: the analysis of customers' types according to 20-80 rules.....	18
Figure 7: The transaction cost framework.....	25
Figure 8: Governance efficacy	30
Figure 9: The comparison of ex ante and ex post for specific assets	30
Figure 10: The efficiency of three transaction modes for different levels of specific assets.....	33
Figure 11: The map of China.....	34
Figure 12: the strategy change of the transaction mode when considering volume of goods and transaction costs	36
Figure 13: The organizational framework of the alliance	40
Figure 14: The distributing map of regional supervising centers and dealing centers ...	42
Figure 15: The sketch map of the network end	43
Figure 16: B2B information platform.....	44
Figure 17: The membership and audit process.....	46

1. Introduction

Research has shown that the purpose of most logistics companies is to reduce costs, increase efficiency and create more value-added service. How to gain more profit and keep their market position are the core problem for the logistics companies to worry about.

For the small-medium sized companies, forming a strategic alliance seems a way to compete with those large-scale companies. The strategic alliance network I is composed of many small-medium sized air cargo service agents covering hundreds of cities nationally. The purpose of the strategic alliance is to form a national logistic distribution network, in order to reduce the transaction costs and increase the competitiveness.

In the real operation, the strategic alliance network I is a relatively primary network which lack of standard criterion, strict supervision and performance assess, and lack of the platform of communication, operation and settlement as well. The alliance did not achieve the original intention due to the extensive management and high transaction costs.

This thesis aims at a series of problems mentioned above, using the transaction costs analysis, such as information asymmetry, small numbers, bounded rationality and opportunism to analyze and solve these problem separately. During the internship in Dapeng, it is possible to build the strategic alliance network II to improve the communication of the information, the efficiency of dealing with the businesses and customers' satisfaction by constructing the information system, supervising the operation process and automating the settlement.

The paper is divided into 8 chapters. Chapter 2 gives a general introduction of the background environment of local small-medium sized air cargo service agents business;

Chapter 3 presents the overview of the strategic alliance network I, gives a case study of Dapeng logistics and figures out the problems they faced; Chapter 4 reviews the research framework and literatures. Chapter 5 analyzes and solves the problems of the strategic alliance network I and Dapeng; Chapter 6 gives the strategies and proposition for establishing the strategic alliance network II; Chapter 7 concludes the thesis by summarizing the study's findings and by identifying recommendations for future operations; Chapter 8 gives a further research for the development of the alliance.

2. Background environment of local small-medium sized air cargo service agents business

With the rapid development of the China's economy, more and more small-medium sized air cargo service agents have emerged within the country recently.

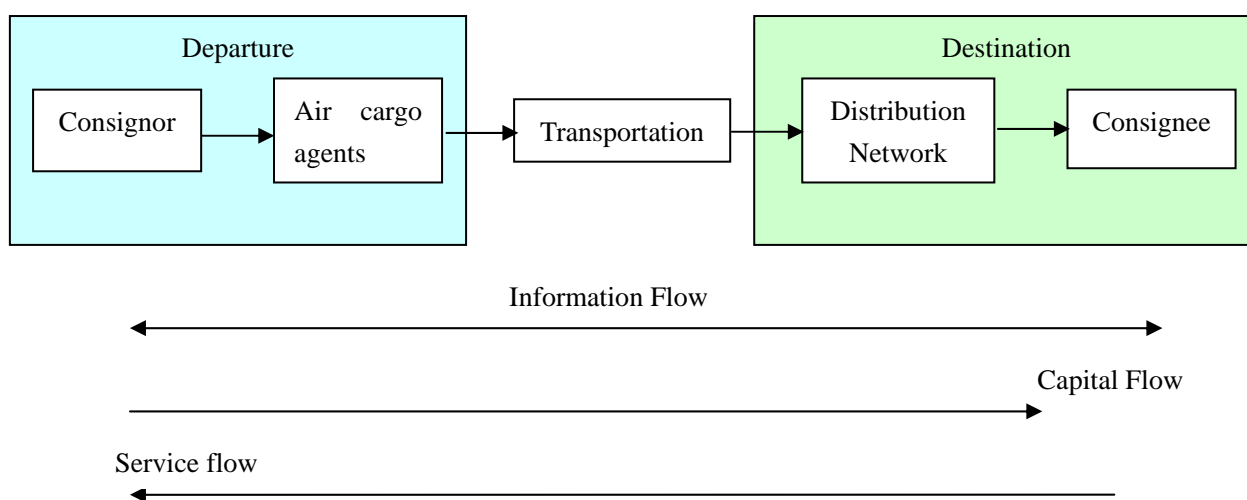

Figure 1: The process of air cargo business

A reliable and complete national distribution network is playing a fundamental part in the competitiveness and development of the air cargo service businesses, due to the air cargo business' specific characteristics of door-to-door services. Limited by the finance, resources, and most importantly, the management skills, it is quite difficult for our local small-medium sized air cargo agents to expand the network extensively across

regions within the country, like what the large-sized state-owned or some international logistic service providers are doing where they are able to provide a full range of integrated logistic services nationally. Instead, small-medium sized private service providers can form alliance with each other, through expanding the strategic alliance network across different regions and providing third party services through brokerage in order to meet the door-to-door services requirements across different regions.

The strategic alliance network is composed by many local small-medium sized air cargo service agents including Dapeng. The strategic alliance has over 200 members, covering over a hundred of cities. This strategic alliance network is the largest based on the number of members and the area covered. However, since the strategic alliance network is formed voluntarily, without either standard regulations or operating rules, nor regulating organizations, and also due to the difference in employees' standards, main goal of businesses, and operating skills, the strategic alliance network looks problematic.

Comparing with the large-scale logistic companies' integrated and regulated national distribution network, "strategic alliance network" is highly fragmented, comprised of many small companies. It is difficult to gain competitive advantages due to their lack of organizational skills, consolidated management skills, and long period of extensive operation. Whether to give up or to improve the strategic alliance network, it is necessary to do an analysis on the current industry environment of the national small-medium sized air cargo service agents through the five forces which affect the industry structure.

2.1 Potential competitors

For any industry, the level of competition from the potential competitors is normally depending on the level of existing entry barrier. If there is high barrier to entry or if they think the current members would defend against their entry extensively, then the

threat from the potential competitors would be small.

For our current air cargo service agents industry which is in its developing period, the barrier to entry is low, since most companies in the industry have no core competitiveness in either finance, technology (exclusive services), or constructing the distribution network. At the same time, because of the severe competition in the market, the newly formed companies are normally not first time entering into the industry. More often, they are separated from within the industry, for example, some previous employees were forming their own air cargo service agents after leaving the companies.

The current small-medium sized air cargo service agents need to make action plan to work on their own limitations, focusing on improving their quality of service and network construction, increase their level of entry barrier, either wise, they would become unattractive due to the increasing number of potential competitors.

2.2 Current competitors

With the industry's constant improving and developing, some much stronger competitors will appear in the market, these companies either have strong capital management skills (i.e. COSCO), or co-investing with foreign companies thus getting more advanced technology (i.e. DHL), or have top management skills (i.e. PGL), or even some top foreign logistic big thumbs have entered into our market (i.e. UPS).

Most of the small-medium sized air cargo service agents can not compete with those strong local competitors as mentioned above at the same level, since those strong local competitors are focusing on competing for the "high price, high quality" high end customer market, they pay little attention to small-medium sized companies' "low price, low quality" middle-low end customers market. In fact, just like "80-20 rule (Pareto Principle)" and "Long Tail Theory" proves, although it is believed that 20% of

the customers are holding 80% of the market share, “long tail theory” tells them that by providing high quality services to those huge number of small-sized customers, they still can hold a relatively large market share.

Those small-medium sized air cargo service agents are now facing the severe price competition from their peer competitors. Along with the increasing demand from the customers, the small-medium sized companies have to learn either “providing same services with lower cost” or “providing better services with the same cost”, in such a way to compete against those large-scale companies entering into the “low price, low quality” market.

2.3 Substitutes

Local small-medium sized air cargo service agents usually provide limited services, thus can not leverage their multi-transportation advantage. Especially recent years, with the rapid development of our highway and railway network, highway freight and railway freight can almost replace air cargo freight, and will further compete against air cargo business in the future.

2.4 Buyers’ market

For small-medium sized air cargo business, their businesses are normally from one or a few high-end customers, or even they are growing depending largely on those big-sized customers, which results in buyers have definite advantages in a deal. Moreover, even if for low-middle end customers, since those small-medium sized air cargo service agents have limited kinds of services and poor reputation, making those customers can easily taking the dominant position due to the strong competition of those small-medium sized air cargo agents.

2.5 Suppliers

As a supplier, distribution network is playing a special role in the process. On the one hand, since the small-medium sized air cargo companies are normally operating at a relatively small-scale, it is difficult for them to provide a high number of distribution businesses, and thus they have relatively low bargaining power. On the other hand, since small-medium sized air cargo agents are usually acting as a third party distributing agent for each other in their local area, they have some common interests, thus they highly dependent on each other. However, because those small-medium sized companies can not truly recognized the importance of their dependence on each other, they normally focus on their short-term benefits during the distributing process, lack of careful strategic considerations for their long-term business.

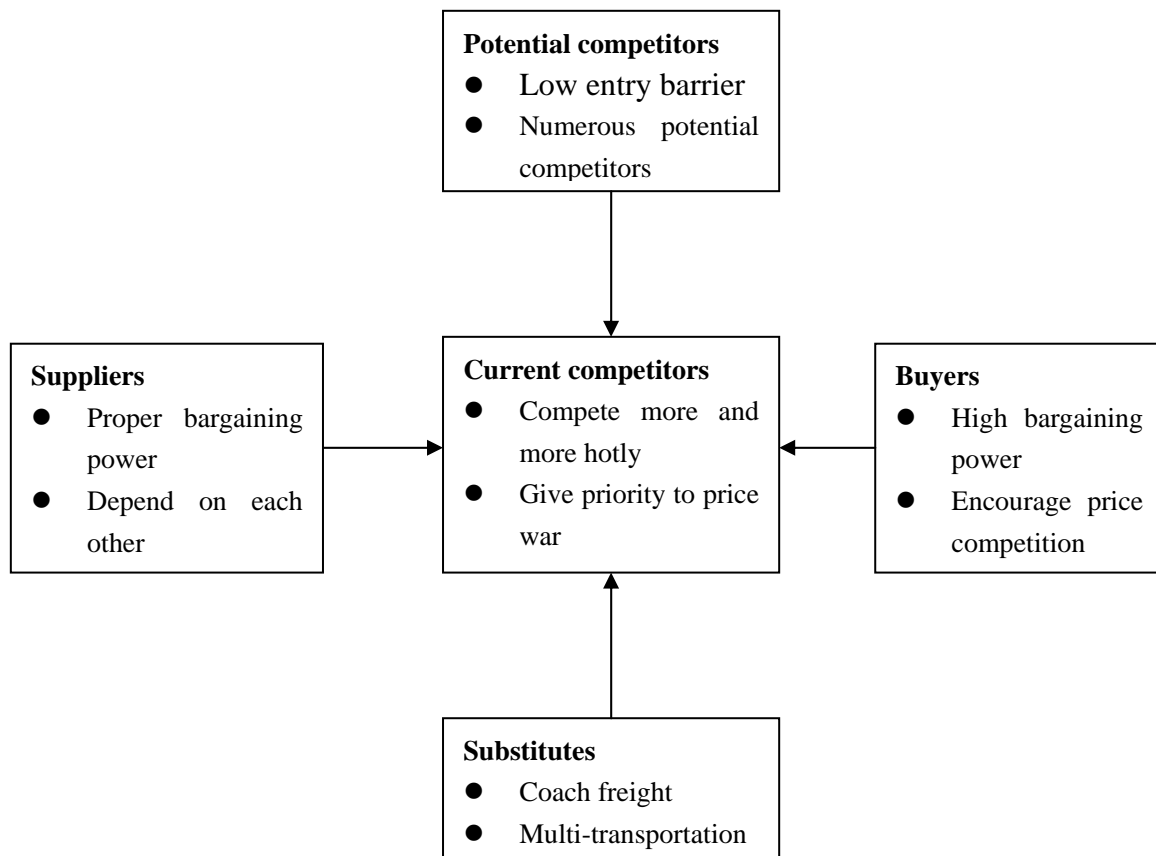

Figure 2: The analysis of the five forces

Based on the above analysis, it is clear to see that facing the high pressure from the

increasing competition and the more severe business environment, small-medium sized air cargo service agents must find a way to both improve their service quality and cut the cost in order to gain competitive advantages. It becomes crucial for those companies to improve the national distribution network management, integrate and consolidate the distribution network, enhance the strategic alliance's cohesion and core competitiveness, in order to make sure their long term existence and sustainable development.

3. The introduction of current strategic alliance network I

“Strategic alliance network” is the strategic alliance of our national small-medium sized air cargo service agents, forming a delivery network composed of around 200 members and covering hundreds of cities nationally. This distribution network, on the one side, can be considered as the largest network, due to the number of members it owns and the area of regions covered; on the other side, however, it has many flaws due to those members' differences in the quality of their employees, management skills and visions of their business leaders, and operating experiences. The four aspects of the strategic alliance network will be analyzed below separately.

3.1 The SWOT analysis of the strategic alliance network I

3.1.1 Strengthens

- Low setup cost. Members who joint in “the strategic alliance network I” do not need initial investment for building the distribution network, as they can simply choose the one member within “the strategic alliance network I” who already has been operating in the region designated by their clients as the one to help them to deliver goods.
- Flexibility of the transaction. Members of the network can change the service provider easily if they feel not happy with the price or quality of the service,

without any inconvenience caused due to procedure restrictions. If they establish their own distribution network, they can not change the providers freely because of no restraint to the provider.

- Most of the members are private companies, thus improving the communications and cooperation.

3.1.2 Weaknesses

- Relatively dispersive members and lack of solidarity apparently. Members focusing more on their own interests, no common vision and standard of service.
- Relatively high operating costs and low efficiency.
- Relatively low competitiveness. Lack of highly experienced senior management team, although many expertise in operating the day-to-day processes; lack of long-term vision for the business and the industry as a whole; simply concentrating on increasing the sales volume rather than developing their competitive advantages.
- Relatively low information technology oriented and lack of the capability for workflow control.

3.1.3 Opportunities

- Most members have realized the importance of a reliable national distribution network in their own business operation and development, thus increase the possibility of rebuilding a more integrated and closed cooperating network.
- Monopoly of the information resources is banned for large-sized logistic

companies. Small-medium sized air cargo service agents can work together and research and develop their own logistic information platform and B2B electronic transaction platform.

- Common demands. It is a good opportunity to develop oneself when cooperating with its strategic partners. The strategic alliance network is the common demand of most small-medium sized air cargo service agents.

3.1.4 Threats

- Some large sized air cargo service agents with strong management skills and financial resources, for example JZS Express, have already started to standardize its information and operating platform through expanding their own businesses into different regions nationally. It is a question of now or never, for those small/medium sized companies to cooperate together and develop themselves quickly to catch up with those large competitors.
- Large sized air cargo service providers are beginning to compete for the medium/low end market, due to their decreasing costs after further integrations. Therefore, the small-medium sized air cargo service agents would quickly lose their competitive advantages once they facing the competition from those large companies.

3.2 The analysis of the competitiveness of air cargo service agents

Air cargo services are usually tailored to a specific customer's requirements, in order to reduce their logistic cost and boost the stocking efficiency. More competitive air cargo service agents are always trying their best to meet customers' special requirements, in such a way to save costs for the clients and leave the clients to their core competitiveness through providing storage management and supply chain

management services. They also provide several value-added services, such as the entire journey tracing, repackaging, the settlement and such services.

Table 1 shows a summary of the questionnaire for the competitiveness of air cargo service agents (The data root in part of the manager of a small-medium sized air cargo service agent). The questionnaire was scoring on the 12 main indicative activities, in terms of their importance, performance, and the performance of their competitors (Take Suzhou Datong as an imaginary competitor here), with highest score of 10 and lowest score of zero.

Table 1: The competitiveness test of an air cargo service agent

Items	Importance	Performance	Competitors
(1)Timeliness	6.8	4.6	5.8
(2)Service attitude	6.6	6.8	6.4
(3)Company image	2.6	3.2	5.6
(4)The feedback of signed documents	4.0	5.1	5.3
(5)Information circulation	3.8	2.0	4.5
(6)The ability of dealing with special affairs	6.4	7.1	5.8
(7)The ability of improving the customers	6.2	5.2	6.5
(8)The settlement efficiency	6.0	4.7	5.8
(9)The distribution ability	5.8	6.8	6.1
(10)The complementary of company and distribution network companies	4.6	4.4	5.7
(11)Distribution cost	5.2	4.6	6.0
(12)The efficiency of dealing with complaints	5.6	6.4	5.4

As a result of using the average opinion method, it is not easy to figure out the extremely good or bad items and the feelings seem not very intensive as a whole. In figure 5, it shows the strong caution to people through the comparison of the

importance of items and the present performance as well as the importance of items and the relative performance (in table 1: the score of performance minus competitors).

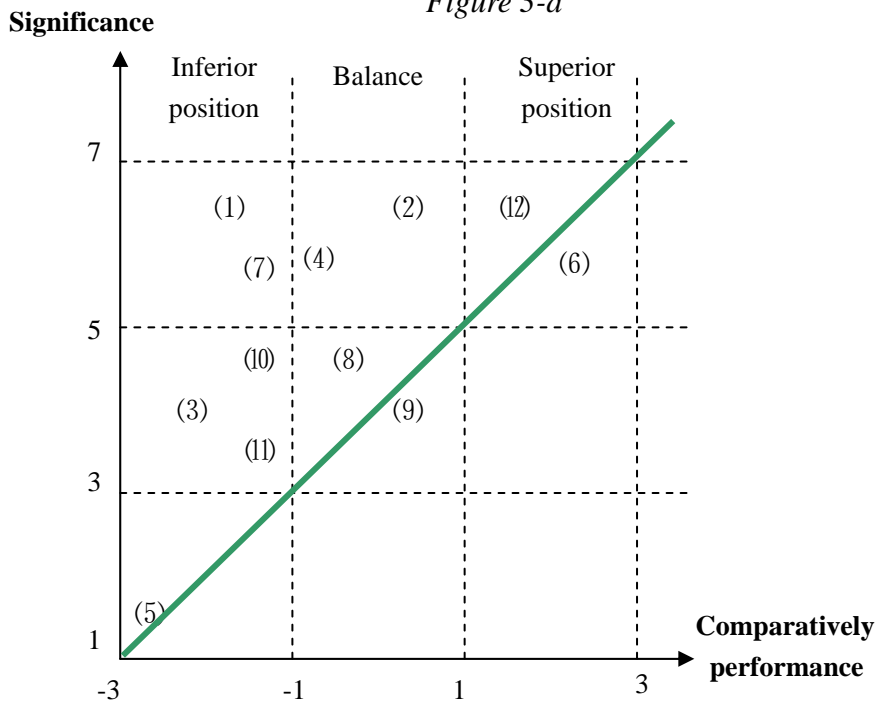
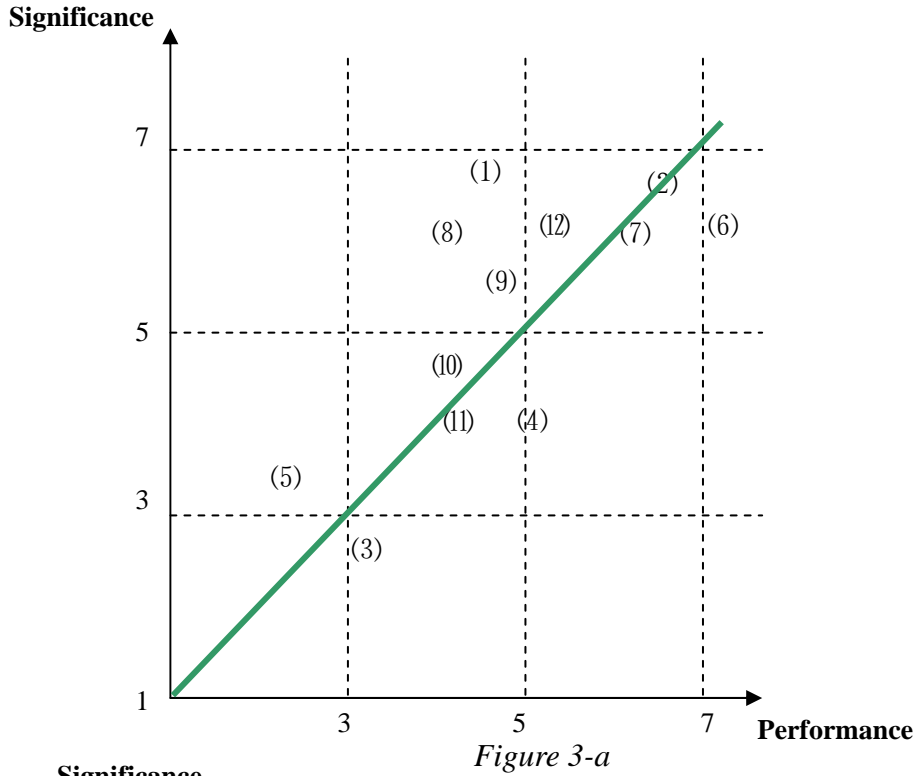

Figure 3-b
Figure 3: The analysis of Dapeng's competitiveness

In figure 3-a, the green line uses to distinguish dissatisfied items and temporary satisfied items. The items above the green line mean dissatisfy, that is the high importance but the low actual performance, while the items below the green line illustrate the high actual performance but low importance (i.e. temporary satisfaction). These two kinds of items almost occupy respectively one half. Moreover, in figure 3-b, there are only two temporary satisfied items (i.e. the ability of dealing with the special affairs and distribution) after considering the competitors; the competitiveness of all the others are dissatisfy. Combining with the other elaborations above, the figure 3-b perhaps reflects the real competitiveness.

The good performance of the ability of dealing with special affairs and the distribution ability can be explained reasonably like this: because of the small and complete organizational structure, the employees can make a quick response to the urgent events. In addition, because it owns 100 city freight taxies and decades of other freight vehicles, it is quite natural that other air cargo service agents can not catch up with it in the ability of distribution in local area.

None of the twelve items displayed in the questionnaire can success without the reliable distribution network. But lack of a reliable and complete distribution network is the ultimate reason for Dapeng that fallen behind the competitors in most of the items.

3.3 Case study of an air cargo service agent--Dapeng

Suzhou Dapeng Logistics Ltd., one of the air cargo service agents will be taken as an example, in order to perform a detailed analysis of the current problems and challenges faced by small-medium sized air cargo service agents. Dapeng logistic Ltd. founded in 1999 with just six employees and one vehicle, in just five years' time, it has been growing rapidly and now posses over 200 employees and approximately 200 vehicles, with 60% market share of Suzhou's logistic industry.

3.3.1 The business process of Dapeng air cargo service agent

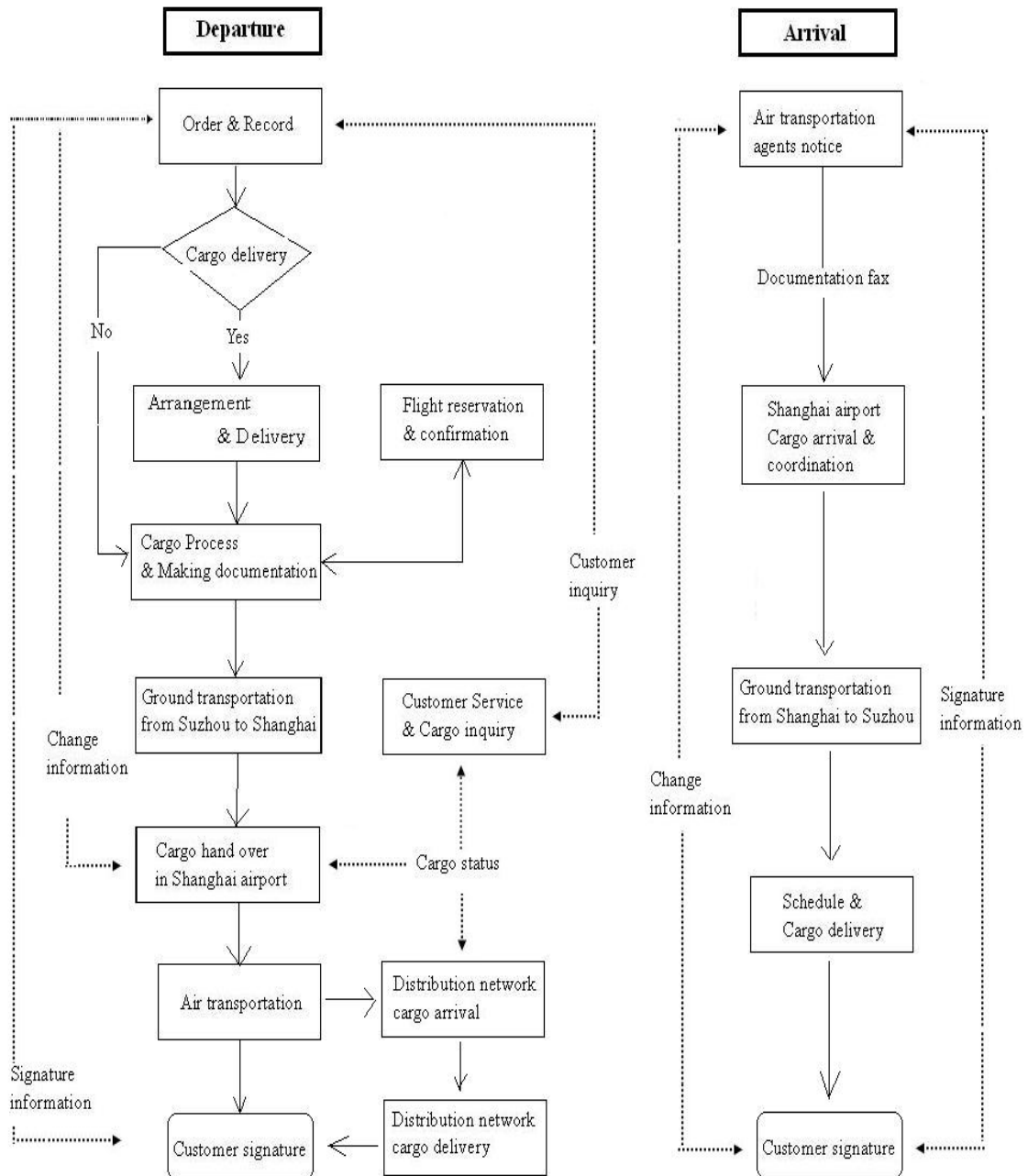

Figure 4: The business process of Dapeng air cargo service agent

The picture above illustrates the goods and information flow of the air cargo service

agent process. In general, the air cargo services of an air cargo company like Dapeng Logistics compose of air cargo exports and air cargo imports. Air cargo export services are responsible for delivering goods outwards from local places, while air cargo import services (i.e. Dapeng Logistics helping other air cargo service agents outside of Suzhou to distribute their goods) are responsible for distributing goods from outside of the region to local places.

However, normally most of the air cargo agents, including Dapeng Logistics, are paying more attention to the air cargo exports services, as export services can not only yield a high margin, but more importantly, the requirements are coming directly from their own clients. Thus, the effects are more severe if there is anything wrong during the whole process. On the contrary, import service is commonly considered as a complementary service. Therefore, competing for the import service is just aiming for increasing the vehicle usage rate, thus reducing the overall operating costs.

The information flow has two directions. The main content of the information flow is tracking and tracing information, i.e. through telephones, faxes, or emails. Dapeng Logistics are thriving to become one of the most competitive air cargo service agents, mainly by means of reducing the clients' logistic costs, maximizing the stock in trade efficiency, providing supply chain management and taking care of the conditions of the clients' goods in order to enable the clients to concentrate on their core businesses. In order to provide high quality information about tracking and tracing, Dapeng Logistics have increased the inquiry desks and call centers. However, how to reduce the cost related to information services and how to make sure the information provided is accurate and up-to-date, are the two most important questions that Dapeng need to think about at the moment.

3.3.2 The present problems of Dapeng

The air cargo service agent business contributes to 80% of Dapeng's total revenue, the

rest 20% is the highway and railway agents businesses. Dapeng has signed the contract about the air cargo exports services with nearly 40 members of the strategic alliance and it can get the imports services from dozens of members.

There are six concerns from the distribution network which Dapeng faced in the operation of the air cargo service agent business:

3.3.2.1 Low efficiency of information services

It is without doubt that the information is quite important in modern society, which can be seen from the customers' increasing demand on the information services. In order to best provide customers with high quality tracking and tracing information, Dapeng has allocated 3 people to the inquiry desk, spending nearly RMB 20,000 each month. However, there is still 1/3 of the information inquiry requests can not be met from time to time.

In the era with internet and ERP, similar to TQM's saying that "quality is free", information is also free. If Dapeng's logistic information platform can be extended to the whole distribution network, in the same time, the relevant information can also be communicated back to Dapeng from the distribution network. The "network hub" mentioned later is a concept that based on a distribution network with shared information resources.

3.3.2.2 Still do the settlement process manually

When settling a deal with another member within the strategic alliance network, it is nearly impossible for them to automate the process using computer, largely due to the large variety of contracts, prices quoted, and standards of settlements that are used by different members. Instead, each deal has to be settled manually, both time consuming and leaving exposure to human error.

Taking the imports service as an example, when Dapeng is getting deal from another air cargo service agent, the price quoted is sometimes different even between today's and yesterday's. Negotiating the deal and the prices is needed all the time.

Dapeng has now allocated 4 people to the deal settlement process; still, the payments and receipts of money are always delayed as each single deal needs to be settled manually. It is believed that other small-medium sized air cargo service agents have been facing the similar problems. Why can not standardize the price and the price expression so that the computer can help to settle the deal automatically instead of human beings? Although the price is not fixed, automatically settling the deal on the internet is still possible if everyone is trading on the B2B platform.

3.3.2.3 Increasing revenue, but decreasing profit margin

Most of the small-medium sized air cargo agents adopt railway and highway freight transportation because of the competition. Although it can increase the revenue, the profit margin drops dramatically, due to the low profit of railway and highway transportation.

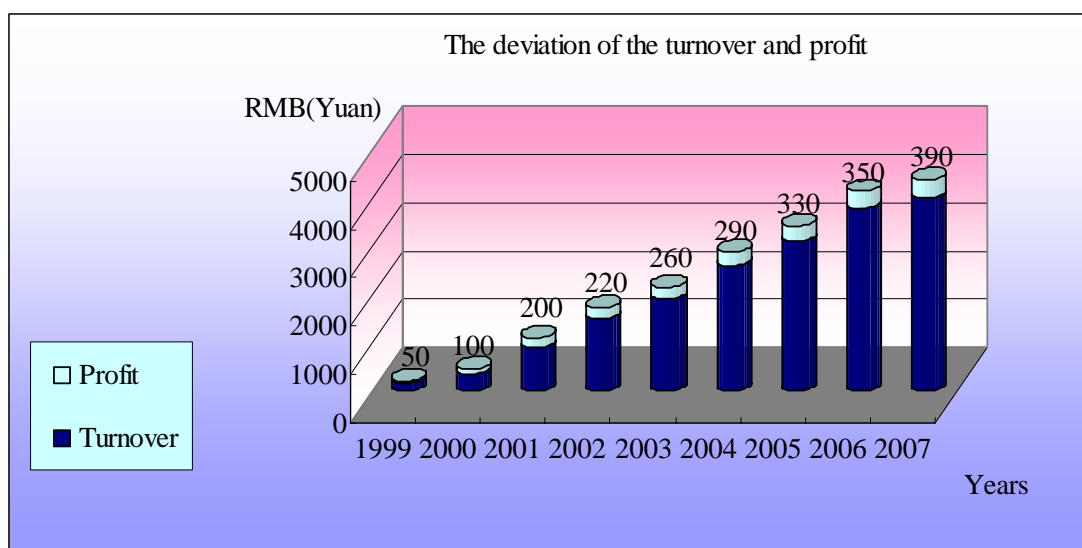

Figure 5: The example of the shrinking profit with increasing sales

Facing the diverging trend of sales and income, most of the small-medium sized air

cargo service agents always dependent on their feelings to process daily businesses, thus they didn't do very well on their financial affairs, operation and they even didn't analyze these data in a penetrating way. They just expanded the scale blindly and used the highway and railway freight transportation instead of the airfreight. However, the competition becomes more intense and the profit is more slender gradually by using these kinds of means. "The multiplication" looks like very attractive, but the small-medium sized air cargo service agents also need to watch out for "the multiplex trap".

3.3.2.4 Lack of standardized quality of services

More small-medium sized air cargo service agents are paying more attention to the number of customers rather than the quality of the customers, ended with having a large number of customers but lack of valuable customers. Having said that, which means those small-medium sized companies are rarely thinking about who should be their target customers and what type of customers are suitable for them.

"20-80 rules (Pareto principle)" is suitable for analyzing the types of the customers. Among the approximately 700 customers of Dapeng, 400 are old customers of which, 300 are loyal customers which still doing business with Dapeng. Among the 300 loyal customers, the top 25 customers by sales contribute to 75% of Dapeng's total revenue; while the next 26th to 50th customers contribute to 15% of Dapeng's total revenue; the rest 250 customers only contribute to a merely 10% of Dapeng's revenue.

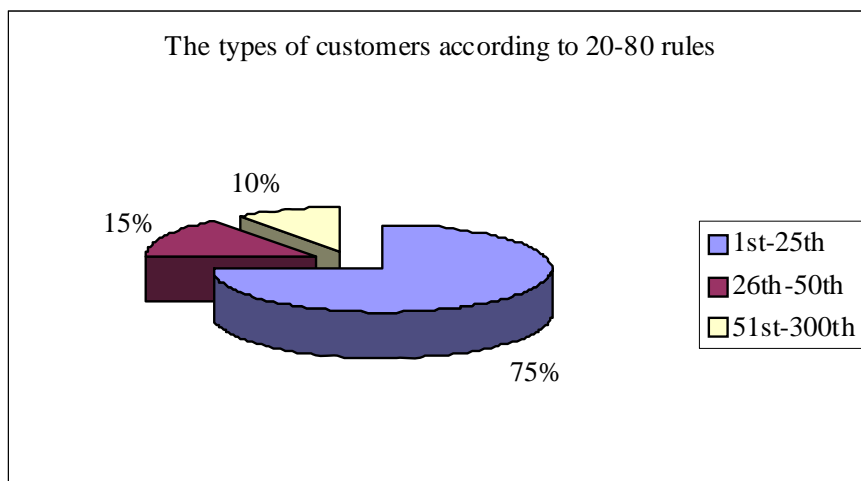

Figure 6: the analysis of customers' types according to 20-80 rules

Further analysis shows that, the small-sized customers contribute to an average sale of RMB120 per deal. However, the cost of providing service to a RMB120 deal is very similar to that of providing service to a RMB3000 deal. That can partially explain why income declines with increasing customers, since sales to small-sized customers are making losses based on the current operating model.

3.3.2.5 High fixed cost and low efficiency

Understandably, the small-medium sized air cargo service agents have to build their own operating system without a shared large-scale operating platform, as opposed to large-sized companies. As such, the fixed cost per service provided is much higher than those with large-scale operation, since large sized companies normally can achieve the economy of scale in order to reduce the fixed cost per service dramatically. Taking Datong, the main competitor of Dapeng, as an example, in terms of logistic, its subsidiary in Suzhou can fully rely on Datong's operation centre in Shanghai. As such, they just need to simply record the deal and take the goods from the customer, leaving Datong to perform all other more complicated processes, such as scheduling and designating vehicles from related area for the transportation between Suzhou to Shanghai. On the contrary, Dapeng has to perform all the processes by itself by setting up a Shanghai branch responsible for sending and receiving related goods. As a result,

there is a huge difference in terms of their efficiencies and costs: Suzhou Datong is generating twice as much as Dapeng's sales with just half of Dapeng's total employees.

Apart from the shared platform, the low efficiency and lack of a sound information management system (MIS) also negatively affect on the cost and quality of services of the small-medium sized companies. It is quite difficult for those small-medium sized companies to find a better way to improve when facing either of the two problems mentioned above.

The three problems mentioned above are mainly about small-medium sized air cargo companies' internal environment. In the Forbes 1000 most efficient companies published every year, there are many small-medium sized companies on the list. That means it still has potential to improve in terms of internal management for the small-medium sized air cargo service agents.

3.3.2.6 No reliable national distribution network

Lack of a reliable and complete national distribution network is the root cause of why it is impossible for small-medium sized air cargo service agents to operate in the high-end logistic market through their normal services or value-added services. Moreover, it is not easy for several small-medium sized air cargo service agents to solve this problem; more small-medium sized air cargo service agents should join them and unify the target to innovate unceasingly.

Talking about the problem of the distribution network at the very end is not because it is not that important, rather, since it is much more vital so that we perform a much deeper and more detailed analysis using a separate section.

4. Methodology and literature review

4.1 Methodology

The thesis starts with the strategic alliance network I to find out all kinds of problems and some insufficient aspects in the operation process. Moreover, take Dapeng (one of the members in the alliance) as a case study to understand and analyze the problems deeply by using TCA and relevant theory. After solving the problems of the strategic alliance network I, the new alliance, i.e. the strategic alliance network II will be built some day.

4.2 The transaction cost analysis

Transaction cost, referring to the direct cost incurred during the transaction process, further decomposed into marketing costs, organizational costs, etc. Transaction costs also include the costs incurred during the process of finding out the relative price, negotiating, signing the contract, motivating and supervising to make sure work can be done according to the contract. According to the transaction cost principles, changes in transaction costs are leading to the changes in organizational structure.

In economics and related disciplines, a transaction cost is a cost incurred in making an economic exchange. For example, most people, when buying or selling a stock must pay a commission to their broker; that commission is a transaction cost of doing the stock deal. Or consider buying a banana from a store; to purchase the banana, your costs will be not only the price of the banana itself, but also the energy and effort it requires to find out which of the various banana products you prefer, where to get them and at what price, the cost of traveling from your house to the store and back, the time waiting in line, and the effort of the paying itself; the costs above and beyond the cost of the banana are the transaction costs. When rationally evaluating a potential transaction, it is important to consider transaction costs that might prove significant.

A number of kinds of transaction costs have come to be known by particular names:

- Search costs are the costs for searching the information of the commodity and trade object.
- Information costs are the costs of obtaining the information of the transaction object and exchanging the information with each other.
- Bargaining costs are the costs required to come to an acceptable agreement with the other party to the transaction, drawing up an appropriate contract and so on.
- Decision-making costs are the internal costs happened when making a decision and signing a contract.
- Policing and enforcement costs are the costs of making sure the other party sticks to the terms of the contract, and taking appropriate action (often through the legal system) if this turns out not to be the case.
- Breach of contract costs are the costs afterwards paid for breaking a contract.

Williamson (1985) further distinguished the transaction cost into two types, which are ex ante and ex post:

- Transaction costs ex ante consists the costs when signing a contract, negotiating, contract guarantee and so on.
- Transaction costs ex post include the costs when the contract being incapable of

the real status, establishing and operating costs, the bargaining costs, obligation costs and the costs for solving the dissension problem between each side.

The reason for transaction costs occurred comes from the market malfunction phenomenon which produces in the interaction of the human nature factor and the transaction environmental factor, leading to the difficult transaction. Williamson (1975) pointed out the six origin of the transaction cost.

- Bounded rationality

Bounded rationality means that the capacity of human beings to formulate and solve complex problem is limited. Some models of human behaviour in the social sciences assume that humans can be reasonably approximated or described as “rational” entities. Many economics models assume that people are hyper rational, and would never do anything to violate their preferences. The concept of bounded rationality revises this assumption to account for the fact that perfectly rational decisions are often not feasible in practice due to the finite computational resources available for making them.

- Opportunism

In Williamson’s view, human beings are not only boundedly rational, they also sometimes display opportunistic behaviour. Williamson describes opportunism as ‘self interest seeking with guile’ and as making ‘self disbelieved statements’. Opportunistic behaviour can occur ex ante or ex post. Ex ante opportunistic behaviour leads to adverse selection and moreover, it can occur only when there is asymmetric information.

- Small numbers exchange

Some transaction processes are much more proprietary, or because of the idiosyncratic, the information and the resources cannot circulate very well, which leads to the reduction of the transaction objects, monopoly and bad operating of the market. Now suppose that there are large numbers of sellers and buyers who trade with each other on a regular basis. Suppose that in a certain town there are 10 dealers in second-hand cars. Suppose you buy a second-hand car. If you have a negative experience with one of the dealers you do not want to buy from him a second time. A dealer who behaves opportunistically will damage his reputation. The dealers know this and you know that the dealers know this, so you tend to believe a dealer when he says that a car has no defects. In this case the problem of opportunism is attenuated, because there are many sellers and because reputations matter. You can save the inspection costs. (Note that you can save the inspection costs only if reputations are important and information about reputations is freely available.) There is problem only if opportunism occurs in conjunction with small numbers of trading partners. This is termed small numbers exchange. If there is only one seller, he does not have to worry over his reputation because you do not have an alternative. In this case you want to have the car inspected, so you have to pay transaction costs.

- Information asymmetry

Information asymmetry models assume that at least one party to a transaction has relevant information whereas the other(s) do not. Some asymmetric information models can also be used in situations where at least one party can enforce, or effectively retaliate for breaches of, certain parts of an agreement whereas the other(s) cannot. In adverse selection models, the ignorant party lacks information while negotiating an agreed understanding of or contract to the transaction, whereas in moral hazard the ignorant party lacks information about performance of the agreed-upon transaction or lacks the ability to retaliate for a breach of the agreement. An example of

adverse selection is when people who are high risk are more likely to buy insurance, because the insurance company cannot effectively discriminate against them, usually due to lack of information about the particular individual's risk but also sometimes by force of law or other constraints. An example of moral hazard is when people are more likely to behave recklessly after insured, either because the insurer cannot observe this behavior or cannot effectively retaliate against it, for example by failing to renew the insurance.

- Atmosphere

The mode of a transaction (that is, whether a transaction is governed by the market or by an organization) is determined by minimization of the sum of production and transaction costs. However, there is another factor that also determines the mode of a transaction. This factor is called atmosphere.

Transaction costs for a particular transaction depend on the critical dimensions of that transaction. There are three critical dimensions of transactions: asset specificity, uncertainty/complexity, and frequency.

- The asset specificity of a transaction refers to the degree to which the transaction needs to be supported by transaction-specific assets. An asset is transaction-specific if it cannot be redeployed to an alternative use without a significant reduction in the value of the asset. Asset specificity may refer to physical or to human assets. Williamson argued that the two most important dimensions of business behavior are the problems of imperfect competition and the propensity to act opportunistically. "Asset specificity" becomes an issue because of opportunism.

- The second dimension of transactions, uncertainty/complexity, needs no further explanation: we already know that bounded rationality is a problem only for

transactions with a high degree of uncertainty/complexity. With the development of capital market and the reform of market economy system, the complexity and uncertainty in economic field becomes increasingly evident, and it comes to be widespread that financial crisis and bankruptcy occurs in enterprises.

- When asset specificity is high we expect transactions to be carried out within organizations rather than across markets. However, to set up specialized governance structure (such as a vertically integrated firm) involves certain fixed costs. Whether the volume of transactions conducted through such a specialized governance structure utilizes it to capacity is then the remaining issue. The costs of a specialized governance structure are more easily recovered for high frequency transactions. Hence frequency is the third relevant dimension of transactions.

5. The solutions for the strategic alliance network I and Dapeng

5.1 The strategies for the strategic alliance network I

5.1.1 Relatively dispersive members and lack of solidarity apparently
(Bounded rationality and opportunism)

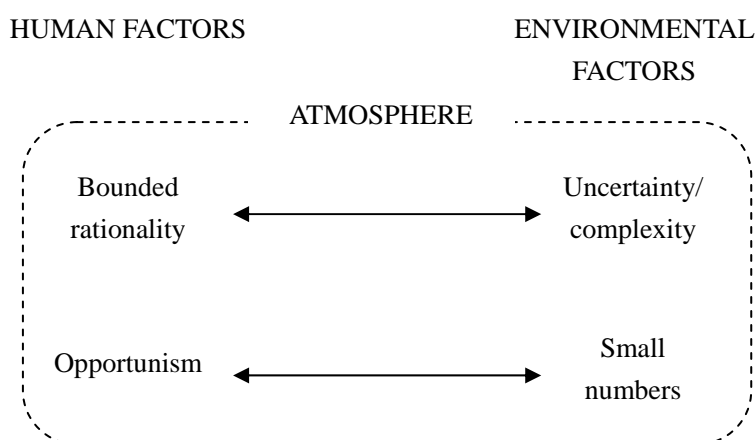

Figure 7: The transaction cost framework

In the transaction costs analysis, the uncertainty and complexity are the environmental factors which will give birth to the bounded rationality; moreover, the small numbers will place a premium on opportunism. However, the members within the strategic alliance network I are relatively dispersive and lack of embedded communications in time, so the phenomenon of uncertainty and complexity will become more and more obvious along with the time. At the same time, some relatively small-sized members are very easy to suspect and defense each other. This phenomenon is the extremely typical bounded rationality and the opportunism.

The bounded rationality believed that the alliance collaborator worried about their core business or customers stolen or missed, so they cooperate with Dapeng carefully. The extremely limited scope of cooperation does not achieve the anticipated effect and even the win-win situation. On the contrary, it also brings the negative influence, for example, the bad service level, the decrease of Dapeng's credits and so on.

According to the opportunism, any side of the alliance will cheat, suspect and doubt its associates in order to going in for profit maximization which will result in the low efficiency of economy and even lost the cooperation. A good example is that one of the members keeps their database as a secret and looks for a new cooperator steering clear of all the other members to prevent the loss of customers. The behaviors above and such behaviors can be considered as opportunism. The member not only increased its costs, but also damaged the foundation of trust and profit among the alliance members. The meaning of establishing the strategic alliance will be bankrupt in as well.

5.1.2 High operating costs (Information asymmetry)

The high operating costs among the alliance maybe caused by lack of the communication and the transaction frequency. Lack of necessary communications and information sharing can lead to the increase of uncertainty and complexity based on

the transaction cost analysis. Take a bill of cargo which be sent from Suzhou to Beijing for example, if both members do bad communications about the flight number, the departure and arrival time, the cargo information and such situations, it will cause the delay of picking up the goods, the shortage of the capacity of the vehicles and so on which lead to a waste of the resources. Not only that, the high frequency of the transaction results in signing a new contract each time. It is also a waste of manpower, material resources and financial resources during this period. Therefore, simplifying the procedures for the long-term frequent cooperation businesses and carrying out the principle of “the first commercial treaty for lifelong benefit” can control the cost expenditure together.

5.1.3 Lack of competitiveness (Small numbers)

Besides the bounded rationality and opportunism which can exist among the members, lack of competitive more or less related with the minority strong enterprises outside the alliance. Like DHL, UPS and such enterprises, they have national distribution network, advanced information system and conveyances, cogent ability of research and development and complete management system for customer relationship. All these advantages are huge strengths to the strategic alliance network. Simultaneously, it is really difficult for the members within the alliance to invest for researching and developing new products and strategies together, because they lacks the unified leadership.

5.1.4 Low information technology

It is quite difficult to integrate the information platform after the construction of the alliance, because each member has their own inner information technology platform before establishing the alliance. How to connect with the system platform of the whole alliance and how to keep their own information safe are concerned by every member. Under this situation, they can hardly compete with some large-scale national cargo

service agents. This kind of problems has been studied in the transaction cost analysis. According to the theory, the alliance should make some specified assets, such as the construction of the information platform, the connection of the system among the members, the maintenance and protection of the inner secret data and so on. The devotion of the financing and the technology is a better way to solve the problem of the information system; meanwhile, it is extremely important to supervise the operation flow ever and again for the mastery of the cargo. This particular problem of Dapeng will be discussed below in detail.

5.2 The feasible solutions for Dapeng

5.2.1 How to improve the efficiency of information services and automate the settlement process

How to improve the efficiency of information services and how to automate the settlement process can be come down to the construction of the hardware, i.e. assets specificity. Through some specific assets, the work efficiency can be improved and the expenditure can be decreased dramatically. According to the transaction costs analysis, we know that among the trade objects, the information cost may exist whether between Dapeng and its customers or between Dapeng and the alliance members inevitably. Increasing the devotion of information communication hardware is the most direct way to reduce the costs. At the same time, the increase of uncertainty and complexity which caused by insufficient information communications will promote the appearance of opportunism.

Manual settlement is slow and inefficient. Investing more IT will help to boost the efficiency of the corporate operation and cooperation among different enterprises, as such improve the profitability. Therefore, settlement automation is the fundamental step for an enterprise's future development. In terms of how to set the standards in order to achieve high quality services, specific assets are needed to form a set of

integrated standard of services and performance, in a way to regulate and standardize the operating work flow and processes, and optimize the whole service assessment system.

Because of the incompatible internal information systems among the strategic alliance network I, the members have to use the telephone to communicate with each other while doing businesses. The level of the information management is extremely low due to this. Not only that, when the business related to the commercial secret problems, it is impossible to open the information system to all the members within the alliance.

When consider establishing the strategic alliance network II, the ex-ante analysis mainly aiming at the construction of the information system which can provide a big information platform for the business network and the communication within the alliance. At the same time, an institution which has independent capability of financial settlement needs to be constructed as well in order to help the members do the settlement for each deal. This kind of institution will reduce the quantity of the original burdensome settlement work among the members, in this way, the transactions become much transparent and the information asymmetry and opportunism can be avoided during the transactions.

The purpose for considering the connection of internal operation system and the big platform is to share the information and realize the trends of the operation about the members and the market demand of each area. The members within the alliance can communicate and negotiate in time with each other, and they do not need to change their primary operation system which avoids the high expense for re-constructing the system. Accordingly, they can minimize their transaction costs in the situation of guaranteeing their own commercial secret security.

Of course, the cost of establishing an information-sharing system for the alliance is

pretty high. Worthy or not for establishing the system will be analyzed through the following model:

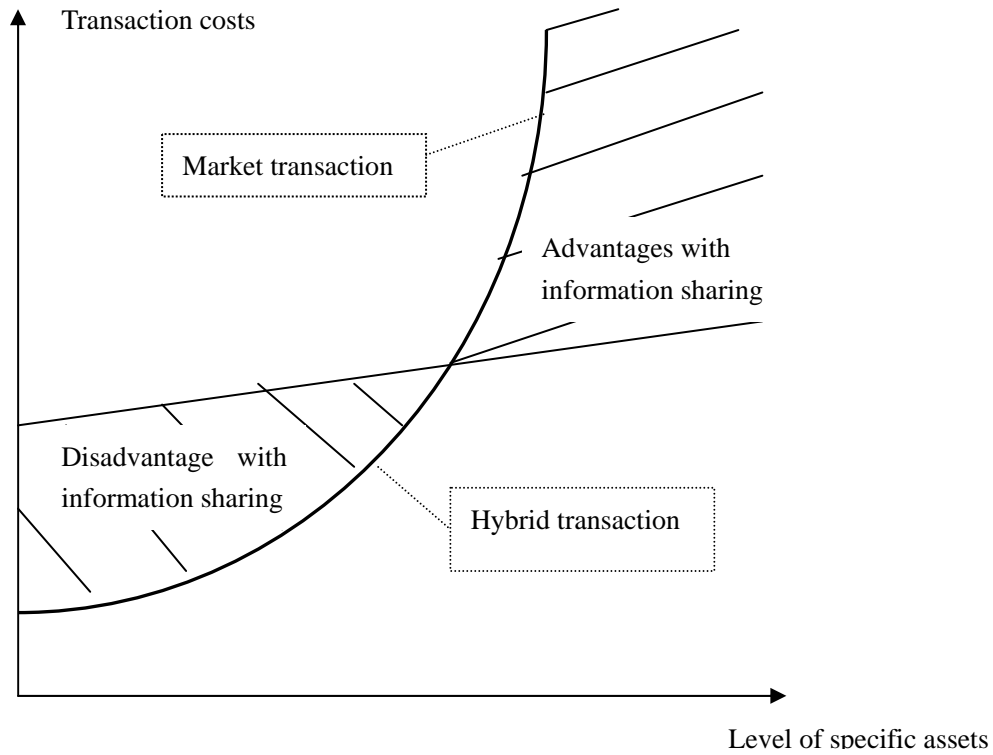

Figure 8: Governance efficacy

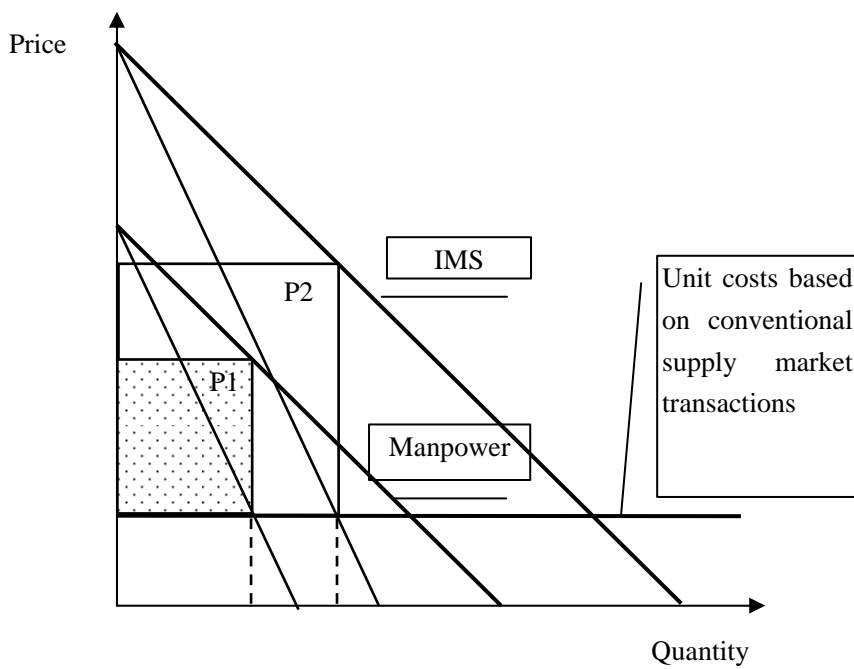

Figure 9: The comparison of ex ante and ex post for specific assets

From the picture above, it can be seen obviously that it is extremely limited for such small-medium sized air cargo service agents to deal with the businesses every day by using original measure to do the information exchanging and businesses. The profit P1 is quite limited as well. After adopting the information system, the quantity of businesses, information and the capability of settlement will improved extensively, as well as the profit 2. The set-up cost for constructing the information system is quite expensive, but after the construction, there is rarely expenditure at all. The only expenditure will be the cost of daily maintenance.

Moreover, along with the increasing portfolio, the way of communication for strategic alliance network I can lead to low efficiency and high cost. Because of the business contacting, Dapeng spends nearly RMB 20,000 each month. However, it still can not meet the customers' satisfaction from time to time. Not only that, Dapeng has employed some professionals to deal the settlement process, even if so, the efficiency is still very low. After adopting the new alliance system, the communication, the operation and the settlement will realize the integration. All the members can improve their efficiency and reduce the transaction costs dramatically, as well as increase the competitiveness for themselves.

5.2.2 How to look on the shrinking profit with increasing sales and lack of high quality of customers

There are various reasons for the shrinking profit with increasing sales and lack of high quality of customers, such as the increase of uncertainty and complexity for Dapeng's providing diversified logistical modes, information asymmetry of the market, the high frequency of the transaction and such reasons. All these reasons are according with the factors from the TCA, so these problems can be solved by the transaction cost analysis.

Dapeng has developed from the cargo agent business to the long-distance cargo transportation, the city distribution and such multiple structures of businesses, thus caused that Dapeng are not able to focus on one or some businesses. Meanwhile, the increase of customers and blindly seeking large-scale leads to running short of the subdivision of the customers which will increase the uncertainty and complexity and greatly improve the transaction costs finally. Most of the customers are individual ones; therefore, it is quite difficult to sign the contract for once. The high frequency of transactions may bring about repetitive costs and will enormously influence the transaction costs ultimately.

The best solution is to classify the customers earlier in terms of ABC analysis. First should be 15% of the customers which are the excellent top customers contributed to 75% of Dapeng's total revenue; while the next 75%'s small-medium sized customers contribute to 15% of Dapeng's total revenue; the rest 10% unstable individual customers only contribute to 10% of Dapeng's total revenue eventually. The emphases of customer service and maintenance should be treated differently according to the customer classification in order to establish a suit of integrated and detailed customer relationship management system. In this way, the objective of high speed and efficiency can be realized by distinguishing the primary and secondary customers and clear processes in the daily transactions.

5.2.3 The analysis of high fixed cost, low efficiency and no reliable national distribution network

The high fixed cost is caused by no reliable national distribution network. So, it is necessary for Dapeng to set up a lot of office and devote some specific assets (including office renting, vehicles, staff and so on) to all the regions. While, the national distribution network is composed of all the powerful air cargo service agents who can make good use of local agents' superiority to achieve resources

complementary and sharing within the country. Certainly, it is unnecessary to have members in each area; meanwhile, it is not suitable to establish alliance in each area as well. Therefore, different situations should have different strategies.

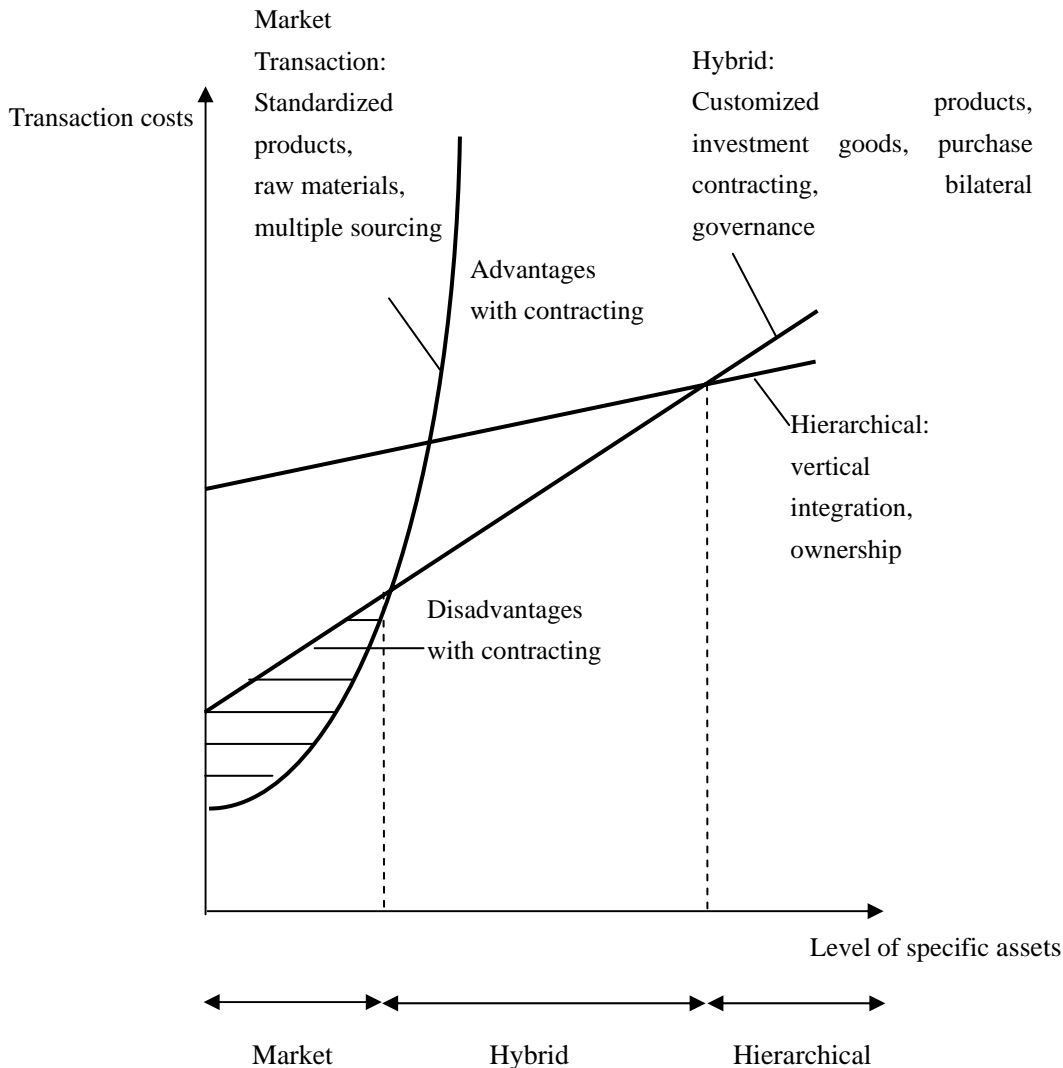

Figure 10: The efficiency of three transaction modes for different levels of specific assets

From the theoretical models above, we will take the practical operation of Dapeng as an example to discuss the cooperation strategy. Firstly, we will choose four representative cities (Shanghai, Beijing, Wuhan and Chengdu) in China and analyze their businesses separately. The map of China is shown below to illustrate the geographical locations of the four cities.

The discussion of how can those small-medium sized air cargo service agents to improve their national distribution network



Figure 11: The map of China

The red panes represent the first-level cities in China (i.e. Municipality), which means the population of the city should exceed 10 million and the total amount of GDP should exceed 900 billion Yuan commonly. Similarly, the green pane represents the second-level city. This kind of cities should generally be the provincial capitals or located in the relatively developed area (i.e. Middle East of China). The homothetic cities are Suzhou, Wuxi, Shenzhen and such cities, which have more than 5 million of the population and 200 billion Yuan of the total GDP. The yellow pane represents the main cities in West China, which means the population should be at least 1 million and the GDP should be 100 billion Yuan upwards.

As known to all, Shanghai is one of the most famous and biggest cities in the world with good facilities of the hardware and software. The air cargo businesses of Dapeng in Shanghai can keep about 20-30 tons each day. Their customers are relatively steady and big, and most of the cargos are export services. Dapeng has established their own management office in Shanghai; therefore, this office can be an example of the costs composing of this kind of offices. The costs table will be shown below:

Table 2: The cost composition

Cost composition	Expenditure(Yuan/year)
Decoration (fixed investment)	100,000
Vehicle(fixed investment)	3x180,000
Lease of housing	120,000
Salary(10person)	200,000

So the annual cost equals $120000+200000+100000+540000=860000$ RMB, due to fixed lay out during the first year, the annual cost of second year should be $120000+200000=320000$ RMB.

Before the office setting, the situation of cooperates with local corporation which means Shanghai local agent. When cooperating with Shanghai agent, 0.2 RMB should be paid for every kilogram to them. Therefore, the expenditure for one year can be calculated. The cost can be shown as follow:

$$\text{Direct Cost}=0.2\text{RMB}\times 25\text{tons}\times 1000\times 12\text{month}\times 30=1800000\text{RMB}.$$

Well then, the fixed cost will be 1800000RMB every year. There will be the same cost as the situation of non office setting only when the freight size of the first year is less than 12 tons ($860000/(12\times 30\times 1000\times 0.2)=12$ tons). In the same way, it is worth to choose cooperator when the freight size is lower than 4.4 tons. Details can be illustrated below:

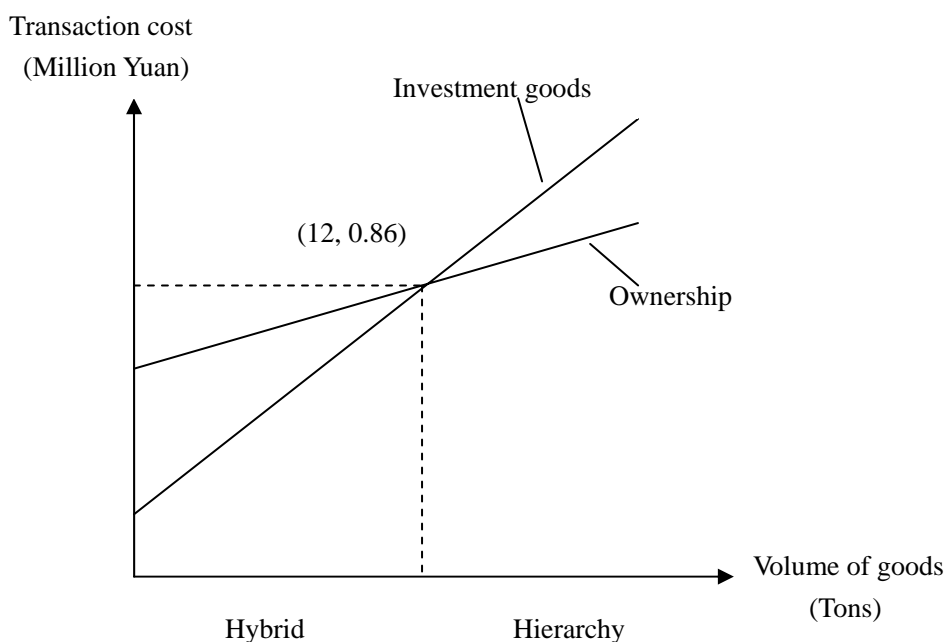

Figure 12: The strategy change of the transaction mode when considering volume of goods and transaction costs

This shows that it can range to hierarchical category according to TCA model which only needs larger investment in the prophase. Therefore, it is obvious that setting up office is more economic than cooperation with others under the guaranty of enduring and business size.

Of course, this is the case in Shanghai because of the short geographic distance to its main office in Suzhou (90KM), now taking look at the strategy considering in the standpoint of the capital city Beijing which also be the same class like Shanghai.

Beijing, as the capital city of People’s Republic of China, has tremendous air cargos daily. It is not only in charge of cargo handling but also responsible for the distribution of Beijing area. The size of Beijing city is around 16,000 square kilo meters, 12 districts contains the population of 15 million. It is necessary to invest 400 vehicles and 500 personnel if Dapeng does really make its mind. Since the geographic distance

between Suzhou and Beijing shows 1200 km, hybrid is advised model in order to overcome obstacle of uncertainty and management problems---find a local potential partner as Dapeng's unit payment committed agency. This method can both achieve cost and risk savings; it also can ensure safety and efficiency of end customer delivery.

Wuhan is in the central of China which has low air cargo size but consider to be one of the largest domestic transshipment site. It connects the communication between northern and southern, eastern and western. The combination of hybrid and hierarchical modes could be a solution to Wuhan's case which is set up own office in Wuhan only for receipt, dispatch and transshipment. Sign subcontract with others relate to the business in the rest cities. Small sizes of specific assets lead to high efficient management and cost intensification.

Chengdu is the capital of Sichuan province which acts as the largest city in southwest of China (Province which suffering the earthquake measured 8.0 on the Richter scale), it close to Tibet, Qinghai, Guangxi and Guizhou Province. Those provinces are low development area with less multinational enterprises. Complicated distribution routings lead to high transportation cost and low cargo loading size because of the highland terrain. So it is seems that the market model is suit for this case. Uncertainty of cargo load, difficulties of transportation and other complicated problems lead to high transaction cost. Therefore, the introducing of the market model is full of flexibility and agility, and the market risk is relatively low.

5.3 Establishing a new-type strategic alliance network II

The strategic alliance network I which mentioned above has already not able to adapt the current developing of the market, even as an alliance which existed in name only. The old alliance does not have core members and unified standard, and what's more, it lacks of information platform, the tracing, tracking and supervising for the operation flow and so on. It is quite necessary to construct a new-type alliance of air cargo

service agents for solving a series of problems above. The next chapter will introduce the discussion of constructing the new alliance which names as the strategic alliance network in detail.

6. The detailed prospect of the strategic alliance network II

6.1 The brief introduction of the strategic alliance network II

The air cargo service agents like Dapeng need to call for the cooperation among the local small-medium sized air cargo service agents, in order for those “strategic alliance network” members to volunteer to work together making effort on constructing a sound “new strategic alliance network” (the updated version of strategic alliance network I, abbreviated as “strategic alliance network II” below) for their common interests.

“Strategic alliance network II” will become an integrated cooperating organization, rather than a “club”, and be formed by previous “strategic alliance network” members who have relatively strong operating skills and good versions of businesses. The major members will not exceed ten, with roughly 10 other minority members.

“Strategic alliance network II” will be operating based on the standardized regulation with the same vision of business. Members in the same region (i.e. eastern china area) will form the same operating platform (so called operating center), providing the high quality services with a fee for members outside of the same region, i.e. distribution supports and freight forwarding services. It encourages the member within the same region can cooperate with each other to come forth one or two large-scale air cargo service agents in each area finally. In this way, the alliance can compete with other large sized air cargo service agents nationally. Moreover, this strategic alliance network II will become a new brand and organizational institution of this industry in a mature time.

6.2 The basic framework of the strategic alliance network II

The strategic alliance network II can be promoted as an absolute large-scale company to operate. The members within the alliance can occupy different proportion of the alliance's stock according to their important extent, market share, profit ability and such terms, forming shareholders general assembly of the alliance. The combination of the 5 to 7 core members which mentioned above are the superior companies in the field of air cargo service agents can constitute the top management of the alliance similarly as a directorate of a company, focusing both on the operation and the future developing strategies for the alliance.

The other numbers of peripheral air cargo service agents which are the A-class companies generally can constitute the operating management department of the alliance. These companies have very good advantages and credits in cargo agent, storage, city distribution and so on. Certainly, there are also other important departments, such as human resource department, IT department, business development department, marketing department, financial department and risk management department. The detailed structures will be shown below:

The discussion of how can those small-medium sized air cargo service agents to improve their national distribution network

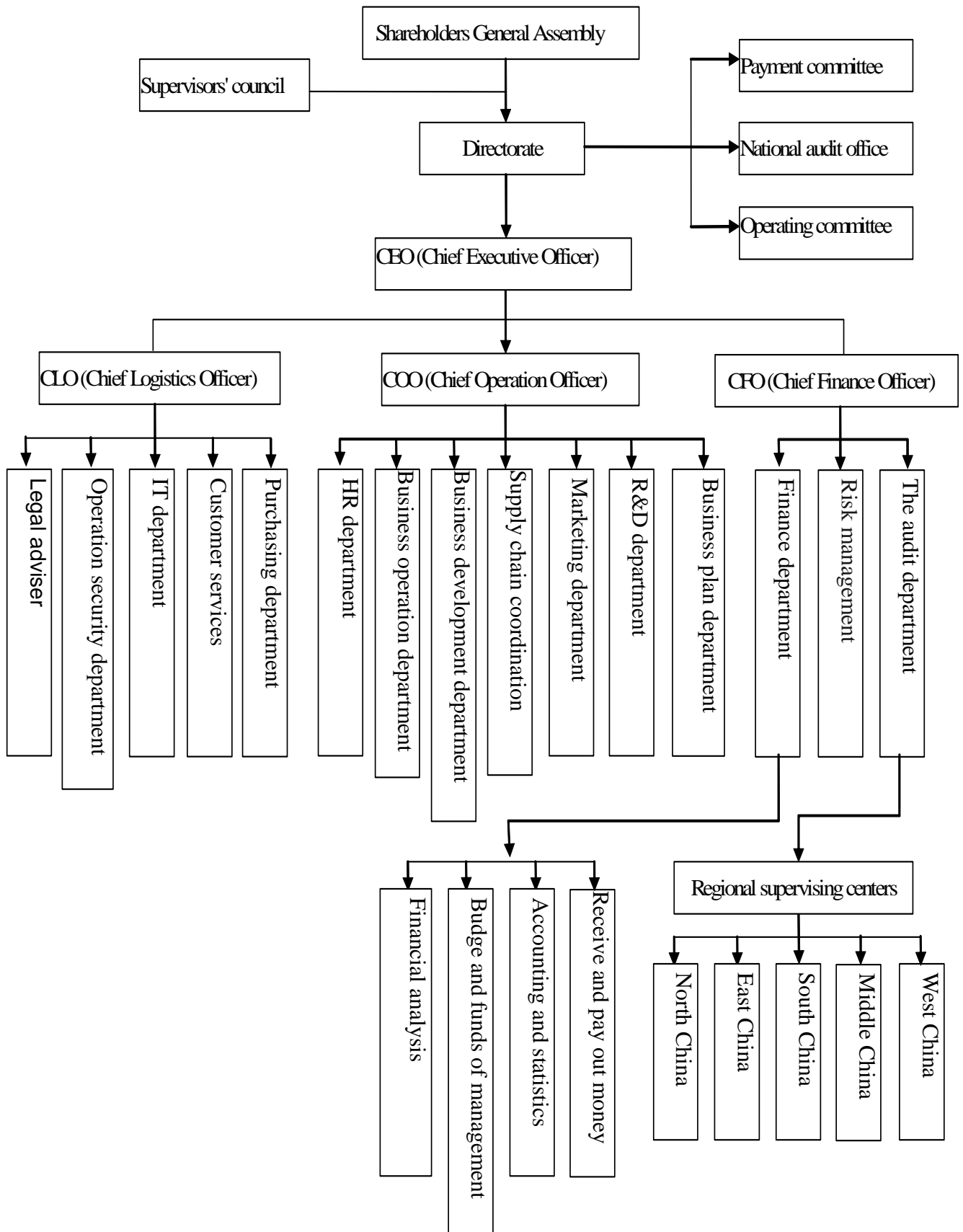

Figure 13: The organizational framework of the alliance

Regional supervising centers also should be formed based on the portfolio and the national distribution network after forming the top management of the alliance. The functions of the regional supervising centers are risk control, financial audit, cooperation and communication, the elementary audit for the new members and so on.

The location of the regional supervising centers will appear the situation of different-degree decentralization and excessive centralization, because the national distribution network involves too many regions. For example, the geographic locations of Zhejiang province, Jiangsu province and Shanghai are relatively centralized and the portfolio of these three places are extremely big; while, the province such as Tibet, Xinjiang, Qinghai, Gansu and Ningxia has extremely large areas, but the portfolios are quite limited because of the small population and undeveloped economy. Therefore, it is quite necessary to establish five big regional supervising centers and dealing centers (North China, Middle China, East China, South China and West China) within the country (See figure 13). In this way, the main work of supervision and accounting management institution will be lighten greatly; what's more, the administrative levels of management system will also be quite clear.



Figure 14: The distributing map of regional supervising centers and dealing centers

6.3 The detailed constructing direction of the strategic alliance network II

6.3.1 The construction of the information system

Dapeng is now updating its logistic information management system, in order to promote its system more easily for connecting with the new alliance. The new system is focusing on improving the management analysis, work flow control and work flow automation processes. In a certain point, Dapeng will pass the use right of the new system to all the "strategic alliance network II" members, in order for everyone can enjoy the convenience of sharing the same information platform.

Developing a new information system is quite necessary for the whole alliance. The

new system will develop the network end to strengthen the management of distribution networks more easily. After connecting the network end and the internet, the members may obtain the cargo information and relevant mission immediately after completing the input of the bill by the air cargo service agent. During the delivering process, the distribution network should update their information to the network end unceasingly. This sort of interaction has realized the newest condition tracking for the cargo.

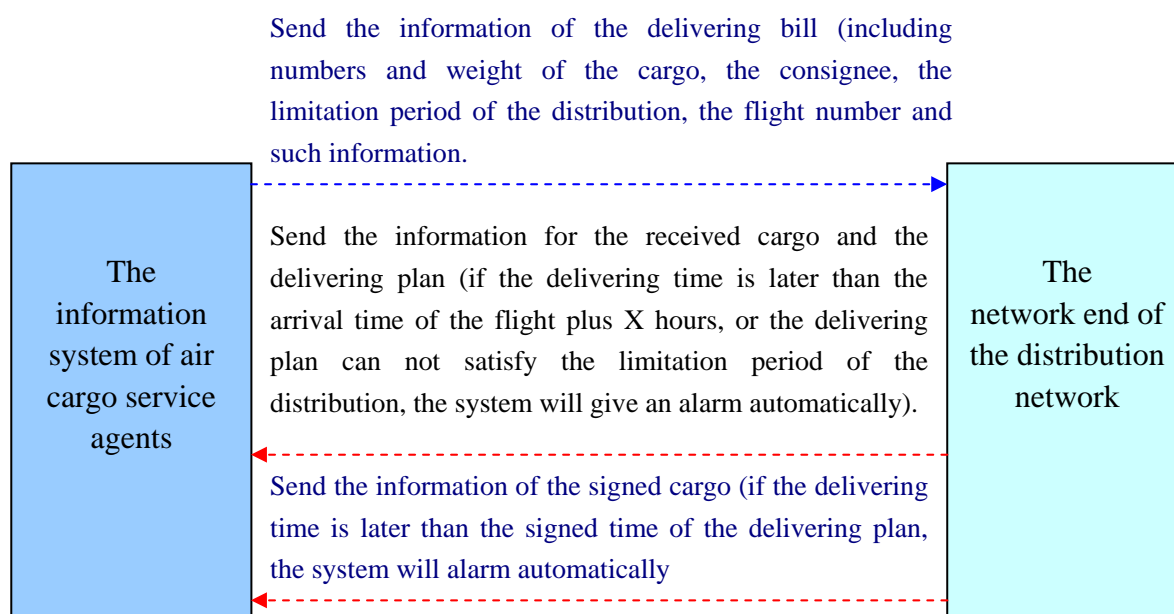

Figure 15: The sketch map of the network end

In the medium-long term, one possible solution for the information platform is to set up a B2B e-business platform for “strategic alliance network II”. This B2B platform is operating and supervising by a third party, providing the following services for “strategic alliance network II” members:

6.3.1.1 The mini-type ERP functional service, likes MySAP

The user just needs to pay a little amount of fee, rather than investing a huge amount purchasing the whole ERP system, so that the management skills and operating efficiency can be increased rapidly. One of the obvious advantages is that everyone is using the system with similar structure; as a result, information can flow much faster

and more smoothly.

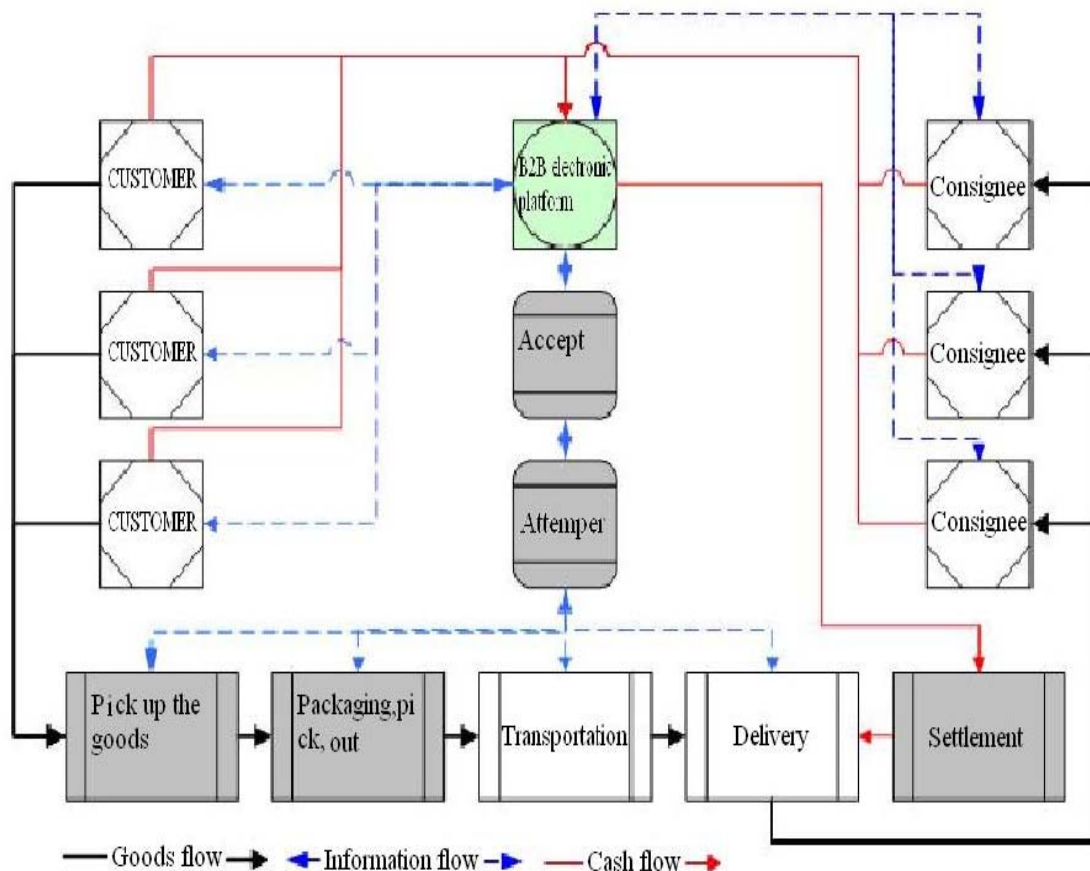

Figure 16: B2B information platform

6.3.1.2 Free trade on the internet

In order to minimize the cost per deal, the way similar to internet auction can be used. For example, for a deal about Dapeng's distributing goods in Beijing, the required services and the quality requirements can be put onto the B2B information platform (the system will acknowledge the members who have meet the requirements), ask for the relevant distribution network to bid for the deal within the required time limits, comparing and picking one from the lowest bidder or the bidder with highest quality/price indicator. As such, Dapeng can minimize their cost while keeping the quality of the service above a standard. To the distribution network in Beijing, the distribution network with highest quality or price who won the bid can make itself much stronger. Indeed, if the bidder can not complete the delivering according to the

scheduled time and the request, they should pay the money for the punishment and reduce their credit record in the system of the alliance.

6.3.1.3 Dealing center's function services

For local small-medium sized air cargo service agents, settlement is not an easy task. This task can be left to a third party "dealing center". This dealing center has two-level framework, one is the regional dealing center which responses for auditing the finance and dynamic supervising within the region, the other one is formed by the alliance's financial personnel and the advanced accountants outside the alliance.

The alliance's dealing center can not only tell when to require payment from clients and how much, but also can automatically balance accounts. Moreover, the dealing center can even help to get payment from other network members, leaving away from those tedious processes. In the near future, the dealing center may develop and provide more value-added services, i.e. account making, dealing with circled debtors/creditors relationship, and short-term financing, etc.

6.3.2 New standard of the integration for the strategic alliance network II (the new alliance)

To ensure the success of network integration and the effectiveness of the integrated alliance network, setting up a sound integration standard and putting effort on the supervision and follow-up process become ever important. There are two main functions of a good integration standard: quality authentication, screening and making sure all the members have all achieved a required level; regulating and supervising, regulating all the members' acts and conducts, making sure the whole alliance network's smooth operation.

6.3.2.1 The standardization of the service system

The quality of services provided between different members within the network is not standardized most of the time; as such strategic alliance network should firstly establish a guideline for standardizing the quality of the services. This standard which almost likes the criterion system of ISO 9001 not only has the strict system of admittance, but also has the complete examine process for the alliance members to ensure developing a normative and healthy alliance.

In today's more severe competition, the one who is more competitive is normally the one who can provide higher quality of services, thus every process within the supply chain is very important. Therefore, the air cargo service agents can not survive by simply improving the quality of its own services; rather, improving every process within the supply chain (i.e. by standardizing the quality of services within the network) becomes very important.

6.3.2.2 Members admittance and intelligence authentication

The companies who want to join the alliance need a suit of strict system of the application and audit. The figure shows as follow:

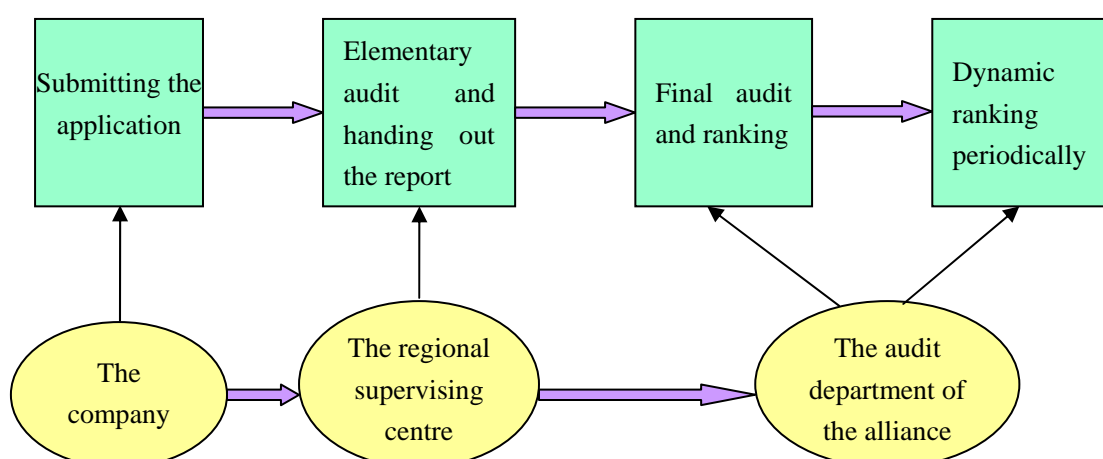

Figure 17: The membership and audit process

The company who applies to join in the alliance should fill in the relative information, respect and obey the alliance's standard, perform its own responsibility, and accept the supervision of the members within the alliance as well as the supervising institution. After the application, the regional supervising centre will elementarily audit the company's scale, the financial statements of recent three years, the credit ranking of the bank, the cooperative record ago and so on. If the company passed the audit, the regional supervising centre should report it to the audit department of the alliance. When the audit department of the alliance receives the report, they will do the final audit to the company.

After passing the final audit, the company will be a member of the alliance and ranked according to its scale, assets, portfolios and the ability of payoff. The audit department of the alliance will also do the periodic dynamic ranking for both B and C-class members. For the members who have big portfolios, good credits and financial statements, the audit department of the alliance can upgrade their rank. Moreover, the members who have bad outstanding achievement and credit will be degraded or dropped out of the alliance. The detailed ranking and grading standard is shown below:

Table 3: The ranking and grading standard

Items	Judging standard (full mark)	Scores
Fixed operation number of years for air cargo	10 years (5)	
Credit records	Excellent (10)	
The perfect degree of management system	Perfect (10)	
The level of information system	Very high (5)	
The level of management team	Professional (10)	
The system and equipment for commodities inspection	Perfect (5)	
Fixed cooperative number of years with the alliance and its members	5 years (5)	
Fixed cooperative number of years with the competitors	5 years (5)	
Management ability	Management expert (5)	
The cooperation with airline companies	Positive cooperation (5)	
Annual profit	10 million RMB (10)	
The annual volume of the air cargos	50 thousand tons (10)	
The scale of own storage	0.1 million square meter (5)	
The registered capital	5 million RMB (5)	
The scale of the company	Large scale (5)	
Total	Full mark 100	

7. Conclusion: The prospect of optimizing the distribution network management

The transaction costs cannot be avoided; however, the main objectives are controlling

the cost greatly, meeting the client's requirements, speeding up the trade flow and information flow between suppliers and clients, and maximizing the profit by using minimum assets. This thesis has analyzed the causes and given the propositions and solutions for the problems above which combined with the transaction costs analysis, through discovering the problems and shortages of the strategic alliance network I as well as its members.

As a local small-medium sized air cargo service agents, the most effective way for them is to enhance their distribution network management, speed up the information flows and cargo flows, meet the clients' demand and requirements, improve their accuracy and punctuality, minimize the operating costs farthest, thus achieve their competitive advantages based on their core services.

It is believed that the network management based on shared information and network integration will dramatically enhance the competitiveness of those small-medium sized air service agents, especially through information platform integration, settlement platform integration, real-time supervision of business flow, inter-firm unification, and ownership infiltration. It is also believed that the new integrated strategic alliance network formed by those small-medium sized air cargo service agents will make them much stronger to compete against those large-scale national logistics companies in the future.

8. Further research

Due to the limitation of research, it provides opportunities for further research. Exploring the new business area and developing the functional areas of logistics companies also need to be carefully considered. Meanwhile, the daily maintenance expense of the strategic alliance network II cannot be looked down upon as well. Therefore, how to maintain the daily operation of the alliance and how to reduce the risk for both members and the alliance should be considered carefully. There are two

aspects for the alliance to do in the future.

8.1 Value-added services

After constructing the strategic alliance network II, the members will become the national leading air cargo service agents and logistics service provider relying on the powerful network team scale and good operation mode. However, in order to keep the competitiveness as well as the alliance's normal operation, some value-added services should be explored, for example, financing logistics.

Based on the good credit, the scale of the alliance and its standard criterion, they can ask for a higher credit application to the bank. Meanwhile, the bank also would like to provide some short-time financing services to the members (those small-medium sized air cargo service agents) within the alliance, because the alliance can provide assurance services to the bank. The innovation of the value-added services and promoting the core competitiveness of the alliance will achieve the blue sea strategy and create excess profit for running the alliance.

It is easy to be found that some small-medium sized customers are always facing some financial problems and can hardly get the short-term loan through mortgaging the enough capital asserts to banks because of the relatively small scale, although they also have good reputation and provide high quality of services/products. Therefore logistic companies could utilize their high level of control over supply chain as an advantage to develop some innovative financial services with banks, which is "personal property financing". "Personal property financing" here means that small-medium sized companies can borrow money from banks backed by their products/stockings while the alliance can provide the guarantee to the banks and help to check and control the borrowers' quality of products/stockings, charging for a fee. As such, the banks are much easier to control the risk and the strategic alliance network can maintain the daily

operation by using the excess income to achieve the win-win situation for both banks and the strategic alliance network.

8.2 Risk limited

There are lots of ways for risk limited, such as the reduction of human errors, flow supervision and so on. One of the important ways is to provide a customized logistics insurance.

In order to limit the risk of customers and the alliance to the lowest level, the demand of the aerial insurance can be provided to the insurance company. In China, the insurance businesses have incompletely covered every industry till now. If the insurance company can measure a set of insurance plan for the air cargo service agents, the clients will not suffer any loss during each link of cargos delivering. The aerial logistic insurance project can reduce the heavy loss for the customers caused by the accidents or the other unknown risks greatly by establishing the project with the insurance company.

References

Aboody, David, and Baruch Lev (Dec. 2000). "Information Asymmetry, R&D, and Insider Gains"PDF (116 KiB). *Journal of Finance*, 9 (6).

Akerlof, G. (1970). The market for lemons: quality uncertainty and the market mechanism. *Quarterly Journal of Economics*, 84 (3), 488-500.

Alvesson, M., and L. Lindkvist (1993) "Transaction costs, clans and corporate culture", *Journal of Management Studies*, vol.30,427-52.

Bob Lowson, R. King, A. Hunter (2001) *Quick Response: Managing the Supply Chain to Meet Consumer Demand* Publisher: Wiley

Bryan Borys and David B. Jemison (1989) "Hybrid arrangements as strategic alliances: Theoretical issues in organizational combinations", *Academy of management review*, vol.14, No.2, 234-49.

Cameron, S. and A. Collins (1997) Transaction costs and partnerships: the case of rock bands', *Journal of Economic Behavior and Organization*, vol.32,171-83.

Cheung, Steven N. S. (1987). "economic organization and transaction costs," *The New Palgrave: A Dictionary of Economics*, v. 2, pp. 55-58.

Coase, Ronald H. (1937). "The Nature of the Firm." *Economica*, N.S., 4(16), pp. 386-405.

Coase, Ronald H. (1960). "The Problem of Social Cost," *Journal of Law and Economics*, 3: pp. 1-44.

Das, T.K. & Teng, Bing-Sheng (2000) A Resource-based Theory of Strategic Alliance. *Journal of Management*. 26(1): 31-61.

Gigerenzer, G. & Selten, R. (2002). Bounded Rationality. Cambridge: The MIT Press; reprint edition.

Hamel, Gary (1991) Competition for Competence and Inter-Partner Learning within International Strategic Alliances. *Strategic Management Journal*. 12: 83-103.

Hayek, F.A (1948) Individualism and Economic order

Jan B. Heide (1994) "Interorganizational governance in marketing channels", *Journal of marketing*, vol.58, 71-85.

Jeffrey H.Dyer and Harbir Singh (1998) "The relational view: cooperative strategy and sources of interorganizational competitive advantage", *Academy of management review*, vol.23, No.4, 660-79.

Jon Elster (1983). Sour Grapes: Studies in the Subversion of Rationality. Cambridge, UK: Cambridge University Press.

Jones, G.R. and C.W.L Hill (1988) "Transaction cost analysis of strategy-structure choice", *Strategic Management Journal*, vol.9, 159-72.

Kahneman, Daniel (2003). Maps of bounded rationality: psychology for behavioral economics. *The American Economic Review*. 93(5). pp. 1449-1475

Maher, M.E. (1997) "Transaction cost economics and contractual relations", *Cambridge Journal of Economics*, vol.21, 147-70.

March, James G. (1994). *A Primer on Decision Making: How Decisions Happen*. New York: The Free Press.

Mas-Colell, Andreu; Michael D. Whinston, and Jerry R. Green (1995), *Microeconomic Theory*. Oxford University Press. (Chaps. 13 and 14 discuss applications of adverse selection and moral hazard models to contract theory.)

Mrinal Ghosh & George John (1999) "Governance value analysis and marketing strategy", *Journal of marketing*, vol.63, 131-45.

Niehans, Jürg (1987). "transaction costs," *The New Palgrave: A Dictionary of Economics*, v. 4, pp. 677-80.

Poppo, Laura and Todd Zenger (1998) "Testing alternative theories of the firm: Transaction cost, knowledge-Based, and measurement explanations for make or buy decisions in information services," *Strategic management journal*, Vol. 9, pp. 853-77.

Porter, Michael E. (1996) "What is Strategy?", *Harvard Business Review*, (Nov-Dec), pp. 61-78.

Rindfleisch, Aric and Jan B. Heide (1997) "Transaction Cost Analysis: Past, Present and Future Applications," *Journal of Marketing*, 61, (October), pp. 30-54.

Rubinstein, A. (1998). "Modeling bounded rationality", MIT Press.

Simon, Herbert (1957). "A Behavioral Model of Rational Choice", in *Models of Man, Social and Rational: Mathematical Essays on Rational Human Behavior in a Social Setting*. New York: Wiley.

Simon, Herbert (1990). A mechanism for social selection and successful altruism, *Science* 250 (4988): 1665-1668.

Simon, Herbert (1991). Bounded Rationality and Organizational Learning, *Organization Science* 2(1): 125-134.

Spence, A.M. (1973). "Job Market Signaling". *Quarterly Journal of Economics*, 83, 355-77.

Stigler, George J. (June 1961). "The Economics of Information". *Journal of Political Economy*, 69 (3), 213-25. (Restricted access; full text requires subscription to JSTOR.)

Sytse, D and Hein S. (2002). "Economic Approaches to Organizations", Prentice Hall.

Tisdell, Clem (1996). *Bounded Rationality and Economic Evolution: A Contribution to Decision Making, Economics, and Management*. Cheltenham, UK; Brookfield, Vt.: Edward Elgar.

Tsang, E.P.K. (2008). Computational intelligence determines effective rationality, *International Journal on Automation and Control*, Vol.5, No.1, 63-66.

Webster, Frederick E. (1992) "The Changing Role of Marketing in the Corporation" *Journal of Marketing*, 56, (October), pp. 1-17.

Wernerfelt, Birger (1994) "An Efficiency Criterion for Marketing Design," *Journal of Marketing Research*, 31 (November), pp. 462-470.

<http://www.szdp56.com/zjdp-dpgk.asp>, the information for Dapeng Logistics,

2008,1,15, refresh.

Williamson, Oliver E. (1981). The Economics of Organization: The Transaction Cost Approach. *The American Journal of Sociology*, 87(3), pp, 548-577.

Williamson, Oliver E.. (1985). *The Economic Institutions of Cpitalism: Firms, Markets, Relational Contracting*. Preview to p. 25. New York, NY: Free Press.

Williamson, Oliver E.. (1996). *The Mechanisms of Governance*. Preview. Oxford University Press.