



# Master's degree thesis

**LOG950 Logistics**

**« Empirical investigation of the return logistics processes: A case study of Elektroimportøren AS»**

Hjelt, Sondre Haga

Ramella, Joachim Andres Lie

Number of pages including this page: 62

Molde, 22.05.18



## Mandatory statement

Each student is responsible for complying with rules and regulations that relate to examinations and to academic work in general. The purpose of the mandatory statement is to make students aware of their responsibility and the consequences of cheating. Failure to complete the statement does not excuse students from their responsibility.

Please complete the mandatory statement by placing a mark <u>in each box</u> for statements 1-6 below.		
1.	I/we hereby declare that my/our paper/assignment is my/our own work, and that I/we have not used other sources or received other help than mentioned in the paper/assignment.	<input checked="" type="checkbox"/>
2.	<p>I/we hereby declare that this paper</p> <ol style="list-style-type: none"> <li>1. Has not been used in any other exam at another department/university/university college</li> <li>2. Is not referring to the work of others without acknowledgement</li> <li>3. Is not referring to my/our previous work without acknowledgement</li> <li>4. Has acknowledged all sources of literature in the text and in the list of references</li> <li>5. Is not a copy, duplicate or transcript of other work</li> </ol>	<p>Mark each box:</p> <ol style="list-style-type: none"> <li>1. <input checked="" type="checkbox"/></li> <li>2. <input checked="" type="checkbox"/></li> <li>3. <input checked="" type="checkbox"/></li> <li>4. <input checked="" type="checkbox"/></li> <li>5. <input checked="" type="checkbox"/></li> </ol>
3.	I am/we are aware that any breach of the above will be considered as cheating, and may result in annulment of the examination and exclusion from all universities and university colleges in Norway for up to one year, according to the <a href="#">Act relating to Norwegian Universities and University Colleges, section 4-7 and 4-8</a> and <a href="#">Examination regulations</a> section 14 and 15.	<input checked="" type="checkbox"/>
4.	I am/we are aware that all papers/assignments may be checked for plagiarism by a software assisted plagiarism check	<input checked="" type="checkbox"/>
5.	I am/we are aware that Molde University College will handle all cases of suspected cheating according to prevailing guidelines.	<input checked="" type="checkbox"/>
6.	I/we are aware of the University College's <a href="#">rules and regulation for using sources</a>	<input checked="" type="checkbox"/>

# Publication agreement

ECTS credits: 30

Supervisor: Berit Irene Helgheim

## Agreement on electronic publication of master thesis

Author(s) have copyright to the thesis, including the exclusive right to publish the document (The Copyright Act §2).

All theses fulfilling the requirements will be registered and published in Brage HiM, with the approval of the author(s).

Theses with a confidentiality agreement will not be published.

**I/we hereby give Molde University College the right to, free of charge, make the thesis available for electronic publication:** yes no

**Is there an agreement of confidentiality?** yes no

(A supplementary confidentiality agreement must be filled in)

**- If yes: Can the thesis be online published when the period of confidentiality is expired?** yes no

**Date:** 22.05.18

## **Preface**

This thesis is the end of a two-year Master of Science in Logistics program at Molde University College. The thesis is researched and written from December 2017 to May 2018.

We would like to thank our supervisors Berit Irene Helgeheim and Birgithe Sandbæk for helpful guidance and good discussions throughout this thesis.

We would also like to thank Elektroimportøren for providing us with data for this thesis and a special thanks to André Swensen for his help with understanding and interpreting the return processes and data from Elektroimportøren.

Furthermore, we would like to thank both the faculty staff and fellow students for two great years and our family for the support they have provided during the study.

May 2018

Joachim Andres Lie Ramella and Sondre Haga Hjelt

## **Abstract**

*The field of return management has become an important supply chain management topic, with the increase of online shopping and the implications it has for allowing product returns. There has been little research on the identification on the costs associated with return management processes. The purpose of this study is to get a deeper understanding of the cost and processes associated with return management. It aims to identify the real costs of allowing product returns for an online retailer. The research is conducted as a case study, using a mixed method approach with data obtained from key personnel at Elektroimportøren and data extracted from their systems. In this research, we identified the business process model for total returns and key cost drivers associated with the process activities. These key cost drivers were identified to be loss in product value, loss of profit, transportation cost and warehousing cost. We were able to find these costs together with identifying the growing trend of product returns and create a forecast for future expected return volumes. We present suggestions for managing the product returns, decrease the volume returned, how to recapture value and improve the return management of the company.*

**Keywords:** *Return management, Product return, Elektroimportøren, Reverse Logistics, Return Logistics, Return Process, Product Returns, Product Complaints, Business Process Model.*

# Table of Contents

1	Introduction .....	1
1.1	Research background .....	1
1.2	Introduction to the company .....	2
1.3	Problem statement .....	2
1.4	Purpose .....	3
1.5	Research scope and limitations .....	3
1.6	Research questions .....	3
1.7	Thesis outline .....	4
2	Theoretical framework .....	5
2.1	Return Management Process .....	5
2.1.1	Types of returns.....	6
2.1.2	Reverse logistics.....	8
2.1.3	Return management processes and activities .....	15
2.1.4	Why product returns management .....	18
2.2	Inventory Management.....	20
2.2.1	Stock.....	20
2.2.2	Warehouse.....	22
3	Data Collection.....	23
3.1	Primary .....	23
3.2	Secondary .....	23
4	Methodology .....	25
4.1	Research Method .....	25
4.2	Induction, deduction and abduction .....	27
4.3	Research Design .....	27
4.4	Research Quality .....	28
4.4.1	Credibility .....	28
4.4.2	Transferability .....	28
4.4.3	Dependability .....	28
4.4.4	Confirmability .....	29
4.5	Calculations .....	29
5	Results .....	35
5.1	The identification of Elektroimportørens returns process .....	35

5.2	Cost results from complaint calculations .....	37
5.3	Cost results from return calculations.....	38
6	Discussion .....	42
6.1	Interpreting the business process model and the costs occurring for complaints	42
6.2	Interpreting the business process model and the costs occurring for returns .....	45
6.3	Potential actions to increase return management efficiency .....	47
7	Conclusion, limitations and further research .....	48
7.1	Conclusion.....	48
7.2	Limitations.....	48
7.3	Further research .....	49
	References .....	50

## List of figures

Figure 1: Comparison of reverse logistics and green logistics. Source: (Rogers and Tibben-Lembke 2001, 131) .....	9
Figure 2: Driving triangle for reverse logistics. Source: (de Brito and Dekker 2003).....	10
Figure 3: Reverse logistics processes. Source: (de Brito and Dekker 2003) .....	15
Figure 4: BPMN of Elektroimportøren returns process .....	36
Figure 5: Total Returns 2015 .....	40
Figure 6: Total Returns 2016 .....	40
Figure 7: Total Returns 2017/2018 .....	40
Figure 8 Visualization of forecast for returns 2018/January 2019.....	41

## List of tables

Table 1: Barriers to Reverse Logistics. Source: (Rogers and Tibben-Lembke 1998, 33) ..	12
Table 2: Estimates of inventory carrying costs. Source: (Stock og Lambert, Strategic logistics management 2001, 195).....	22
Table 3: Complaints products with a sales price less than 200 NOK .....	37
Table 4: Complaints for products with a sales price of minimum 200 NOK - External Manufacturer .....	37
Table 5: Complaints for products with a sales price of minimum 200 NOK - Private Labels .....	38
Table 6: Total Cost for complaints for Elektroimportøren May 2015 - February 2018 .....	38
Table 7: Sale of returned products as new vs. Second-hand.....	39
Table 8: Warehousing costs annually for returned products if sold in 1 month .....	39
Table 9 Forecast values for returns 2018/January 2019.....	41



## **List of abbreviations**

B2B: Business to business

B2C: Business to customer

BPMN: Business process model notation

ERP: Enterprise resource planning

GARS: Global Asset Recovery Services

GSCF: Global Supply Chain Forum

KPI: Key performance index

NOK: Norwegian kroner

SCM: Supply chain management

WEEE: Waste Electrical and Electronic Equipment Directive

# 1 Introduction

This introductory chapter provides the research background, an introduction to the company, the problem statement, the purpose for our study, research scope and limitations, research questions and an outline for the thesis.

## 1.1 Research background

There is a lot of excitement in the e-commerce business these a days. Smartphones as platform is about to take off and there is an increase of nearly 40 percent shopping online more than one time each month for the first quarter of 2017, compared to the year before (Bring Research 2017). This means increased revenue for the companies operating within the e-commerce business, but also that the customers are becoming more professional and more conscious of where they spend their money (Bring Research 2017).

From the customers point of view, it is advantageous to actually see, feel and sometimes try the product before they purchase it. One of the biggest advantages, however, is having the ability to return products should it not satisfy its intended purpose. The internet, on the other hand, is advantageous because it drastically reduces the search cost and is open 24 hours each day, seven days a week (Mukhopadhyay and Setoputro 2004).

In a survey done by (Trager 2000) and (Pinkerton 1997) more than 70 percent said they were to consider the return policy of the company before making a purchase. Product returns can therefore be a significant competitive advantage, which (Rogers and Tibben-Lembke 1998, 222) also found, where 64.9 percent of the respondents thinks that a clear and attractive return policy is important to stay competitive.

For retailers, distributors and manufactures returns have often been seen as a nuisance, a cost center and an area of potential customer dissatisfaction. Customers have viewed product returns as a necessary evil, a painful process and, usually, unavoidable. As long as products are sold, there will always be returns (Stock, Speh og Shear 2006).

From the company that is conducting e-commerce point of view, a return policy constitute a trade-off. A generous return policy is a proven tool to increase customers confidence, and would increase sales revenues by attracting more customers to buy. However, it would also increase the cost of business substantially (Mukhopadhyay and Setoputro 2004).

To the best of our knowledge, not much research has been conducted in the area of how the generous return policy affects a company. We are therefore interested in looking at the cost

drivers and identifying the return process for a company. Through discussion with Elektroimportøren, we decided to look at their return process and identify the cost drivers for their return policy.

## **1.2 Introduction to the company**

Elektroimportøren AS is a Norwegian wholesaler and retailer for electrical equipment, established in 1994. The company operates 12 retail stores across Norway that is integrated with their Norwegian online store, providing both Business-to-Business (B2B) and Business-to-Customer (B2C) customers options for their needs. They had a turnover of roughly 600 million NOK in 2017 with over 6000 stock keeping units available through their stores. They are planning to expand their retail outlets with another 20 warehouses by 2022. They offer products for both professional customers and private customers. Elektroimportøren estimates that 57 percent of their customers are private individuals, while the remaining 43 percent is split between different types of professional customers, with electricians being the largest customer group with 11 percent.

Their product mix consists of 36 percent electrical material, 20 percent cables, 19 percent lighting articles, 11 percent temperature and ventilation with the remaining 14 percent being various types of products.

Elektroimportøren holds a very special position in the market compared to many of their competitors as they operate as both a retailer and a wholesaler, enabling Elektroimportøren to reach out to a wide variety of customers. All Norwegian companies selling products online are bound by law to offer a right of withdrawal to their customers within 14 days (Lovdata 2014), Elektroimportøren has taken this further to be the desired solution for their customers, providing them with a 60-day open-purchase timeframe for returns, free of charge, as Elektroimportøren covers the return transportation cost. Their online store accounts for the second largest volume for Elektroimportøren and is thus more susceptible for products return through that channel compared to traditional channels such as retail warehouses. Research provided later in this thesis shows the difference between expected returns for traditional warehouses and online stores.

## **1.3 Problem statement**

Elektroimportøren is currently not using any information system to keep track of their total returns and the implications this has for their financial results. We hope to find some of the

cost drivers for return logistics and come up with an effective manner to calculate what it really costs to allow your customers to return their products within a given timeframe. We aim to research the loss of profit they experience due to product complaints, the warehousing cost for their returned products, and the transportation cost of maintaining this return policy and how this could evolve in the future. We will look into two different types of return: product return and complaints. By product returns, we refer to when a customer has bought a product and wishes within the given timeframe to return the product for a full refund. By complaint, we mean a product that is returned because it is something faulty with the product and that it does not serve the need it is supposed to serve. One example of this could be a wireless router not being able to transmit the wireless signal to other units. Product returns are usually sold either at retail price or for a discounted price, while complaint products usually are sent back to the manufacturer or disposed of.

## **1.4 Purpose**

The purpose of this research is to gain a deeper understanding of the return management process and Elektroimportørens product return process. It seeks to investigate the cost drivers that are associated with the return of products and the cost of complaints associated with the return. Further, the research will look at data provided from Elektroimportøren and identify cost and trends for products returned. This thesis will only focus on one company to present useful findings and results.

## **1.5 Research scope and limitations**

This study focuses mainly on the return management operation and product returns. The study is limited to the Norwegian market and focuses only on Elektroimportøren as a case study. There is also limited amount of information available to see if the return policy adopted by the company influences the customer loyalty.

## **1.6 Research questions**

To successfully answer the problem statement, the following research question will be addressed:

*What are the key cost drivers for Elektroimportørens return processes and is it possible to identify these costs in a business process model notation?*

In order to answer the research question, the following objectives will be covered.

- What is the return management process?
- What types of returns exist?
- What drivers, barriers and activities envelop the return management process?
- Why should a company accept product returns?
- What inventory costs envelop product returns?

## **1.7 Thesis outline**

This thesis is composed of seven main chapters as follows:

*Chapter 1* introduces the thesis. The background for our research, the problem statement and research questions.

*Chapter 2* presents the theoretical framework for the research by reviewing literature regarding the return management process and related concepts. We define reverse logistics place in the supply chain and touch on inventory management as well.

*Chapter 3* presents the data collection method and what sources of information used to gather primary and secondary data.

*Chapter 4* presents the research methodology. The design of the research and quality of our findings within this thesis. This chapter also explains how we have executed our calculations.

*Chapter 5* contains the results of our calculations presented separately by complaints and returns and also the identified business process for product returns.

*Chapter 6* contains the discussions of the results and how we interpret the results we have found.

*Chapter 7* is the conclusion chapter in our thesis and presents our opinion on what our results mean. We also suggest further research in this section and explain the limitations of our study.

## 2 Theoretical framework

This chapter starts by defining the return management process and what activities it envelops and highlights opportunities that the return management provides. We then differentiate between the different types of returns. Then we describe reverse logistics and what it means within return management and how it is different from green logistics. We describe the drivers and barriers of reverse logistics before we go through the processes and activities in return management. We also highlight why companies want to be handling product returns. Finally, we describe some terms and costs related to inventory management.

### 2.1 Return Management Process

Returns Management is the supply chain management process by which activities associated with returns, reverse logistics, gatekeeping and avoidance are managed within the company and across key members of the supply chain (Rogers, Lambert, et al. 2002). Often used interchangeably with the term “reverse logistics” the return management process is defined as that part of supply chain management that includes returns, reverse logistics, gatekeeping and avoidance. The return management process is one of the eight key supply chain management (SCM) processes described by The Global Supply Chain Forum (GSCF) (Lambert 2004). The proper implementation of this process enables companies to manage the reverse flow efficiently and it enables the companies to identify opportunities to reduce unwanted returns and to control reusable assets such as containers. (Lambert 2004). Return Management is described as a critical SCM process, which requires planning and effective execution throughout the supply chain. The effective implementation will give executives the ability to identify productivity improvement opportunities. This requires interaction and coordination between supply chain members. Returns management also encompasses activities such as avoidance and gatekeeping. Both central elements to effective management of the return flow.

To implement return management process the managers, need to measure the financial impact of returns on the company and other members in the supply chain. Effective management of returns provides an opportunity to achieve a sustainable competitive advantage (Rogers, Lambert, et al. 2002), (Lambert 2004).

The bullet points below adapted from Stock et al. (2006), “returns by the numbers.”

Represents significant costs and, if properly managed, the opportunity for significant benefits.

- Reverse logistic costs account for 0.5 percent of total United States Gross Domestic Product.
- Average return rate for online retail sales is 5.6 percent, although it varies by product and time of year.
- 95 percent of consumer would rather return a product purchased over the internet to a physical location, 43 percent would always use that option if it were available.
- Cost of processing a return can be 2-3 times that of an outbound shipment.
- 37 percent of online buyers and 54 percent of online browsers were deterred from buying online because of return and exchange processes that were too difficult.
- The average cost of processing per return for items bought on the internet is \$30-\$35.
- Liquidators and outlet stores, as outlets for returned or unsold goods, buy these products at only 10-20 percent of their original value.

A newer research done by Bring Research in 2017 also gives some pointer about good return solutions for web shopping and customers expectancy in Scandinavia (Bring Research 2017).

- 60 percent checks the return terms before they shop in a new web store.
- 80 percent of those over the age of 60, checks the return terms.
- 71 percent of the Norwegians, experience a completed return label as simple return.
- 41 percent of the Norwegians, experience the possibility to reuse the package for product returns as simple return.
- 44 percent of the Norwegians, experience that being credited for the return quickly as simple return.

### **2.1.1 Types of returns**

There are many types of returns that need to be managed within this process, each of which poses unique challenges. Product returns can be categorized in two different groups depending on what the company can do with them:

- *Controllable returns* can be avoided or eliminated by actions taken by the company. These returns are a result of problems, errors or difficulties of the customer or seller and can mostly be eliminated with the proper strategies and programs by the company and supply chain members. Controllable returns can be

minimized or eliminated by taking proactive actions, dealing with the root cause of the problems.

- *Uncontrollable returns* cannot be eliminated by the company in the short run, and therefore these returns are often unavoidable. These returns should be handled by eliminating the root cause for controllable returns while simultaneously developing optimal processes for handling uncontrollable product returns. (Stock, Speh og Shear 2006)

(Rogers, Lambert, et al. 2002) Group returns into five different categories as presented below.

#### **2.1.1.1 Consumer Returns**

Consumer returns due to buyers' remorse or defects are generally the largest category of returns. A normal retail store may get returns of about 6-10 percent, while this number may be increased up to 30 percent for online stores (Nairn 2003).

#### **2.1.1.2 Market returns**

Marketing returns consists of products returned from a position downstream in the supply chain, often due to quality issues, poor sales, or the need to reposition inventory. Market returns also include: close out returns, which are quality products that the distributor or retailer no longer wish to carry; buy-outs or "lifts", where one manufacturer purchases a retailer's supply of a competitor's product to get access to shelf space; job-outs, where seasonal merchandise is returned after the season's end; and overrun and surplus. According to (Rogers, Lambert, et al. 2002), market returns can represent a significant percentage of sales.

In addition to returns driven by market issues, some marketing returns are driven by management practices. This can for example be, end-of-quarter loads returned to achieve short-term financial results, which could produce high return rates. Management should be aware of the cost of these returns to determine if artificially loading these channels is worth the long-term costs versus the short-term benefits.

#### **2.1.1.3 Asset returns**

Asset returns consist of the recapture and repositioning of an asset. These are typically items the management want returned to the company. Typical categories that fall within asset



management are reusable containers and repositioning of an asset. Assets such as racking systems can help reduce the overall delivery cost while it is also more environmentally friendly than for example cardboard packaging.

#### **2.1.1.4 Product recalls**

Product recalls is a type of return that is usually initiated because of safety or quality issues. These returns can be initiated by government agencies but can also be voluntary. These types of returns normally require a good amount of planning and contingencies is therefore central to manage them efficiently.

#### **2.1.1.5 Environmental returns**

Environment returns includes the disposal of hazardous materials or abiding by environmental regulations. These returns are often different from others because they can be regulated government agencies, which limits the set of options. Documentation and audit requirements are often necessary.

### **2.1.2 Reverse logistics**

The theory of reverse logistics is fairly old. One of the oldest definitions of this process comes from (Lambert and Stock 1982, 19) where they state that reverse logistics is “going the wrong way on a one-way street because the great majority of products shipments flow in one direction.” This is a rather similar definition that was later produced by (Murphy and Poist 1988) where they defined it as “movement of goods from a consumer towards a producer in a channel of distribution.” Reverse logistics was often thought to be limited to the movement of goods from consumer and back to producer, but in (Rogers and Tibben-Lembke 1998, 2) they came up with a new definition that was perhaps more enveloping the possibilities within reverse logistics. They defined it as “The process of planning, implementing, and controlling the efficient, cost effective flow of raw materials, in process inventory, finished goods and related information from the point of consumption to the point of origin for the purpose of recapturing value or proper disposal.” This was later criticized by (de Brito and Dekker 2002) as the previous researchers made no mention of the possibility of returns being generated anywhere in the supply chain and could be delivered anywhere upstream from that point, meaning not just the traditional backwards movement of goods from consumer and back to the point of origin. Their definition wanted to illustrate the fact that reverse logistics focuses on activities that aim to recover value and maintain proper disposal. “The process of planning,

implementing and controlling flows of raw materials, in process inventory, and finished goods from a manufacturing, distribution or use point to a point of recovery or point of proper disposal.” The scholars also wanted to highlight the difference between waste management and reverse logistics, as the former aimed only to lessen the environmental impact of reverse logistics, while the latter focused on recapturing the economic value or the ability to reuse the product.

There is also the need to differentiate between reverse logistics and green logistics, to avoid any confusion. Green logistics or environmental logistics is the SCM practices that reduces the environmental and energy footprint from logistical activities. While reverse logistics is “The process of planning, implementing, and controlling the efficient, cost effective flow of raw materials, in-process inventory, finished goods and related information from the point of consumption to the point of origin for the purpose of recapturing value or proper disposal”, presented by (Rogers and Tibben-Lembke, *Going Backwards: Reverse Logistics Trends and Practices* 1998).

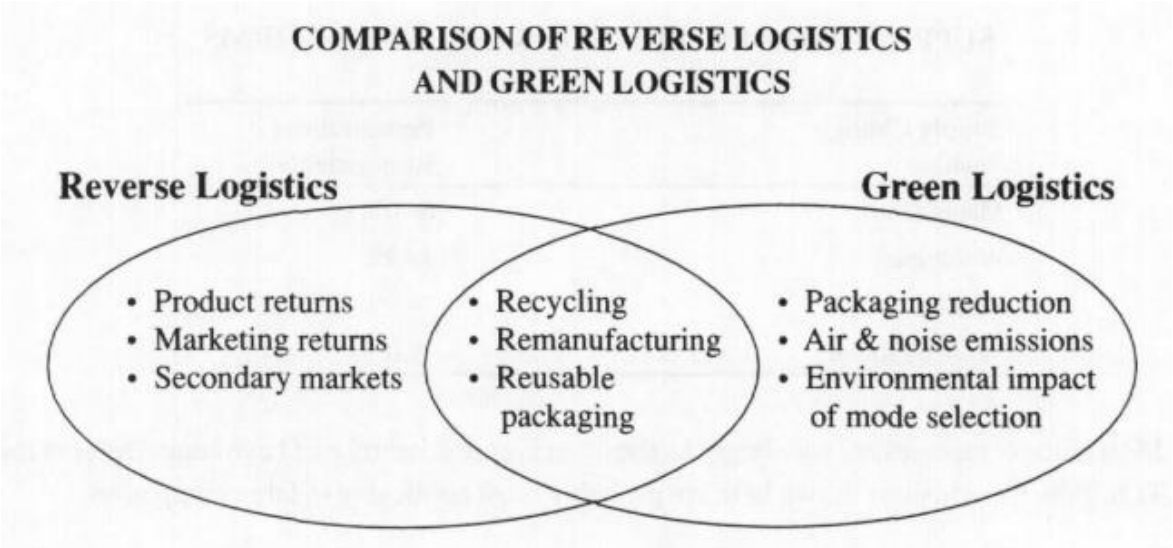

Figure 1: Comparison of reverse logistics and green logistics. Source: (Rogers and Tibben-Lembke 2001, 131)

The article presented by these researchers aimed to differentiate reverse logistics from green logistics by stating that reverse logistics focuses on increasing value and saving money by using or reselling materials to reduce operational cost or recover lost profit. Green logistics on the other hand focuses on recycling and re-use as well as using environmental friendly modes for transportation. Green logistics concerns both the downstream and upstream flow within the supply chain, while reverse logistics mainly concerns itself about the flow going back upstream in the supply chain (Rogers and Tibben-Lembke 2001, 131).

### 2.1.2.1 Drivers of reverse logistics

(de Brito and Dekker 2003), along with other researchers such as (Gupta 2013) argue that there are three main drivers that forces companies to start working on reverse logistics processes. (de Brito and Dekker 2003) Has highlighted these three drivers in figure 2 below. Figure 2 aims to visualize the effects the three drivers has on each other and that they all affect each other.

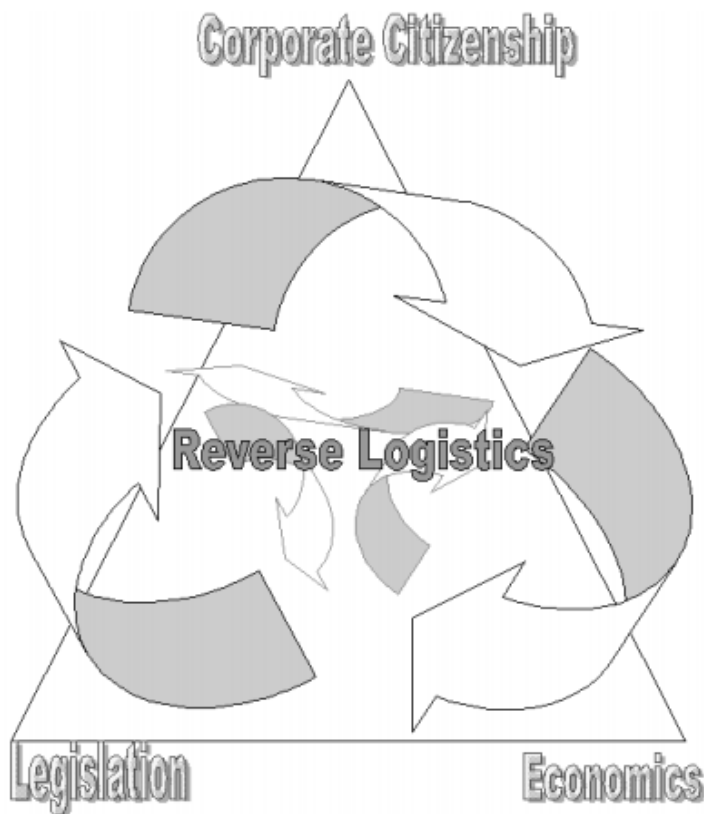

Figure 2: Driving triangle for reverse logistics. Source: (de Brito and Dekker 2003)

#### 2.1.2.1.1 Economics

When looking at reverse logistics from the receivers perspective, such as a wholesaler or a manufacturer, these are often the causes for engaging in these activities; profit, obligatory forces and social pressure. Many of the activities listed above could be included into the economic driver. Being able to handle reverse logistics in an effective manner can often provide substantial gains to the respective company. One way of doing this is to reuse products rather than producing completely new, often providing a lower material cost. One example provided in literature of this is from (Fleischmann, et al. 2000), where he studies Xerox and Canon and their copy machines. Xerox was able to save several million dollars annually because they were able to reuse some of their products. Same goes for Canon who were able to recover and reuse nearly 20 million ink cartridges in 1997, reducing their

production costs as these used cartridges were able to go back in rotation with minor repairs and refurbishing. This example highlights one of the reasons scholars such as (Lee og Lam 2012) and (Gupta 2013) is considering the economic factors as the most important driver for reverse logistics as a company is able recapture value, often-significant values. Increased competition and lower margins in many markets has taken a toll on profit and this is one way to be able to benefit the bottom line. (de Brito and Dekker 2003) Classified the economic drivers into two parts; direct and indirect benefits. For direct benefits a company could experience reduced use of raw materials, add value through recovery and save some of the costs it has previously experienced when it comes to disposal of recycled products. Another possibility is to enter secondary markets with products who has been repaired or refurbished, as this can be a viable option to regain some of the production cost and repairing cost, rather than recycling the entire product. Indirect benefits could be that they receive a green image because of their reverse logistic activities, which could improve customer and supplier relations. (Fleischmann, et al. 2000) also provided an excellent example of indirect benefits for a company; the ability to recall a product so that competitors are not able to have their products, which was done by IBM when they created their own unit to handle reverse logistics, GARS (Global Asset Recovery Services).

#### **2.1.2.1.2 Legislation**

Legislation is the term used for juridical regulations addressing the recovery process of different products or recalls from companies (de Brito and Dekker 2002). Legislation like this is often attributed to come from government pressure and the increased awareness in regard to the environmental aspect, which has resulted in companies attempting to improve their return process in order to make reverse logistics sustainable (Mafakheri og Nasiri 2013). Previously, companies would have no more responsibility of a product once it left their production facilities, and if for some reason, they took the products back they could easily dispose of them in a landfill. There has however in recent times been introduced strict regulations concerning the environment, which has put a limit on these old practices. This has forced companies to prioritize what they can use the landfills for, while at the same time looking for other options on how to handle their returned products. Certain types of products, which contains hazardous materials, are often banned from landfills (Schatteman 2003). Regulations is becoming more and more normal when it comes to disposal of products, like the manufacturer's take-back responsibility, which transfers the responsibility of proper disposal back to the original manufacturer (Bonev 2012). The European Union has implemented

several regulations and directives aimed at controlling the return flow of products, forcing manufacturers to consider the environment in their supply chain. This has resulted in the Waste Electrical and Electronic Equipment Directive (WEEE), which was created in July 2012 (European Commission 2016).

### **2.1.2.1.3 Corporate Citizenship**

Corporate citizenship is the third driver for reverse logistics and is related to the concept of adopting reverse logistics through a set of corporate values. These values are incorporated into their strategies as a way to operate in an environmental and social friendly way, showing the company’s respect towards the environment and society (Gupta 2013). This helps the company develop a green image, which can satisfy consumers expectations, creating a competitive advantage (Bonev 2012). Other scholars argue that having and maintaining a green image can significantly influence the companies’ ability to retain customers and protect the brand image (Rogers, Lembke and Benardino 2013, 42).

### **2.1.2.2 Reverse Logistic Barriers**

Although effective handling of reverse logistics can result in benefits for the company, it is not without its challenges and barriers. According to Rogers and (Rogers and Tibben-Lembke 1998, 32-33), the most common barriers when it comes to the implementation of reverse logistics is how the importance of reverse logistics compared to other issues, the lack of systems in place to handle it, company policies, management support, financial resources, legal issues and competitive issues as seen in table 1. They found these to be some of the most common reasons after examining 300 companies in different industries.

**Barriers to Reverse Logistics**

<b>Barrier</b>	<b>Percentage</b>
<b>Importance of reverse logistics relative to other issues</b>	<b>39.2%</b>
<b>Company policies</b>	<b>35.0%</b>
<b>Lack of systems</b>	<b>34.3%</b>
<b>Competitive issues</b>	<b>33.7%</b>
<b>Management inattention</b>	<b>26.8%</b>
<b>Financial resources</b>	<b>19.0%</b>
<b>Personnel resources</b>	<b>19.0%</b>
<b>Legal issues</b>	<b>14.1%</b>

*Table 1: Barriers to Reverse Logistics. Source: (Rogers and Tibben-Lembke 1998, 33)*

#### **2.1.2.2.1 Lack of Company Awareness**

(Rogers and Tibben-Lembke 1998, 33-34) Argues that many companies do not consider reverse logistics as a priority and they struggle to justify the costs of it, compared to potential gains. Some companies also consider returns as a failure and therefore they do not want to focus on enabling it. In addition to this, (Erol, et al. 2010) argues that many managers are not interested in reverse logistics because they fear that if their products use recycled materials their customers will perceive the value of their products lower than if it was to be completely new, thus lowering the value of the brand.

#### **2.1.2.2.2 Company Policies**

Companies sometimes develop policies that are restrictive and constrains their ability to efficiently handle and recover value from returns. (Ravi and Shankar 2005) States that one of the main reasons for these policies is because companies fear using used materials in the manufacturing and thus possibly negatively affect the quality of the end product.

#### **2.1.2.2.3 Lack of training and support for personnel**

A critical requirement for successfully implementing reverse logistics is that the staff handling the logistics is properly trained on how to manage the reverse flow of goods. Employees not properly trained or encouraged often becomes an impediment to the return process (Cojocariu 2013). (Ravi and Shankar 2005) Also, found that employees are often reluctant to change, especially employees who lacks training and education. Therefore, it is often needed much support from the management to change the mindset of the employees in order to affect their efforts towards reverse logistics.

#### **2.1.2.2.4 Lack of Systems**

Another major barrier presented by (Ravi and Shankar 2005) is the lack of information systems that is advanced enough to create the framework for implementing reverse logistics. A system like this will help the company track products throughout the supply chain and specifically the backwards flow of goods, including forecasts for what kinds of return is expected. Both groups of scholars, (Rogers and Tibben-Lembke 1998, 34) and (Richey, et al. 2005) argues that another problem related to information systems is that many of the existing systems is primarily focused on supporting the forward flow of goods in the supply chain and do not include the return flow, thus lacking the flexibility that is required for reverse logistics.

They proceed their argument that such flexibility is needed in reverse logistics as these processes have numerous exceptions and is therefore very hard to standardize.

#### **2.1.2.2.5 Performance Metrics & Key Performance Indicators (KPI)**

(Ravi and Shankar 2005) Proceeds to discuss that the lack of KPI can be major barriers as they state that a process which is not measured cannot be managed effectively. They state that a prerequisite for managing and improving the performance of reverse logistics is to be able to measure the performance.

#### **2.1.2.2.6 Financial resources**

While (Ravi and Shankar 2005) states that the financial aspect is not a major barrier, it is still an important factor to take into consideration. The financial constraint of implementing a new system and training the staff to operate it can be considerable, especially for a company where there is not much support from management on the issue of adapting an effective role for reverse logistics.

#### **2.1.2.2.7 Legal Issues**

(Rogers and Tibben-Lembke, Going Backwards: Reverse Logistics Trends and Practices 1998) Identified legal issues as another challenge for reverse logistics. Many companies starts with reverse logistics as an answer to government legislation and pressure from environmental organizations and not because of the economic benefits that is available to them. (Erol, et al. 2010) Found that when there is a lack of government legislation it often leads to unwillingness for companies to implement reverse logistics.

#### **2.1.2.2.8 Lack of Awareness**

(Blumberg 1999) Identified public awareness as a driver for implementing good reverse logistics. The creation of public awareness is often rooted in imposed regulation coming through government legislation that pushes manufacturers in the direction of products that are more environmentally friendly and easier to recycle. (Erol, et al. 2010) Found that there is a positive correlation between public awareness of environmental protection and the introduction of environmental legislation.

#### **2.1.2.2.9 Problems with the incentives system**

(Rogers, Lambert, et al. 2002) Argues in his research that it is the goal of the sales personnel to push as much product as possible into the supply chain, as their incentives are linked to the

generation of revenue and they do not consider returns. This can often result in high rates of return because the pipeline is overloaded with products. It is therefore important for companies that their sales personnel are aware of the cost of unloading too many products that may be returned back to them.

**2.1.3 Return management processes and activities**

The return management process involves different activities to capture value and avoid costs of returned products. De Brito and Dekker (2003) provides a model for reverse model processes shown in figure 3. This model consists of collection, inspection/selecting/sorting, recovery and redistribution (de Brito and Dekker 2003). Rogers. Et al. goes further in explaining these processes and start the activities at developing return avoidance strategies, gatekeeping rules and disposition guidelines. (Rogers, Lambert, et al. 2002). We will explain these terms further in this section.

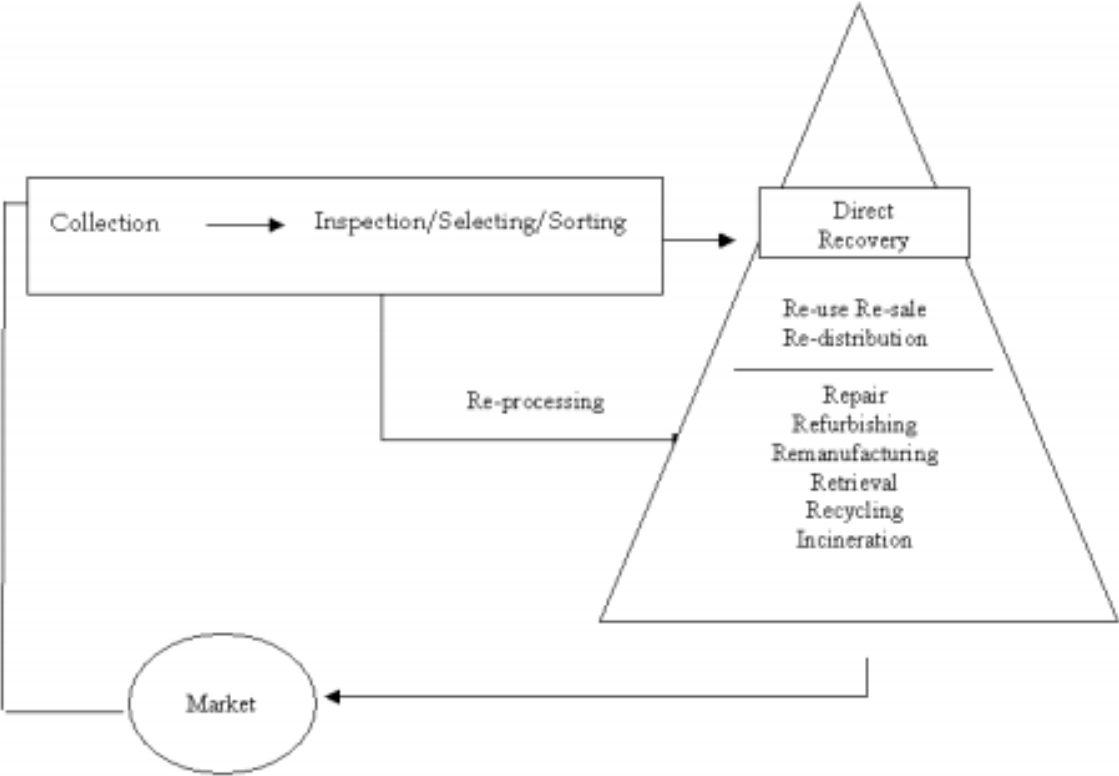

Figure 3: Reverse logistics processes. Source: (de Brito and Dekker 2003)

**2.1.3.1 Return avoidance**

*Return avoidance means developing and selling the product in a manner such that return request are minimized. This is a critical part of returns management and differentiates this*



*process from reverse logistics and the traditional view of return.* (Rogers, Lambert, et al. 2002).

There are numerous ways a company can achieve a reduced number of returns. By improving the quality of the goods and materials, the customer gets a more durable product and thus reduce the returns. Another way is to provide easy to understand instructions. There are many cases where customers have returned the product because they thought it was broken, when in reality, they did not understand how to operate the product. Consistency of products is also important in return avoidance, especially in the catalog business. When customizers order clothes based on size and there is variation due to inconsistencies from the producer, the customer is likely to return the product to switch it to the right size. (Rogers, Lambert, et al. 2002).

### **2.1.3.2 Gatekeeping**

*Gatekeeping is the screening of both return request and the returned merchandise.* (Rogers and Tibben-Lembke, *Going Backwards: Reverse Logistics Trends and Practices* 1998, 38). The first form of gatekeeping can intervene and block the return as early as when the return request is initiated. By providing technical support to assist the customer, the return can be averted. Gatekeeping is also deciding which products that can enter the reverse channel flow. This is decided by the companies return policies. By preventing unwanted returns to enter the reverse channel, the company can improve their disposition of warranty goods. This will also eliminate unnecessary costs to the company. Gatekeeping can take place in different parts of the reverse flow and there can be more than one in the supply chain. Frontline personnel and store-level clerks are often unable or unwilling to gatekeep returns. Once a product has entered the return stream, the re-evaluation to determine if it is qualified, is usually not taken. This is undesirable because the return keeps picking up extra costs as long as it is in the reverse flow stream. This means that the sales personnel have a responsibility and power to avoid unnecessary cost. Management must facilitate so that the sales personnel are aware, have the necessary information and empowerment to make the right decisions. (Rogers, Lambert, et al. 2002).

### **2.1.3.3 Collection**

*Collection refers to bringing the product from the customer to a point of recovery* (de Brito and Dekker 2003).

Collection refers to all operations associated with making the products available and physically moving them to some point for further treatment. Generally, collection may involve storage, transport and purchasing activities. Collection may also be imposed by legislation (Fleischmann, et al. 2000).

#### **2.1.3.4 Inspection/sorting/selecting**

Inspection, Sorting and Selecting represents all activities to determine if the product is reusable and in which condition it is. Thus, inspection and selecting results in splitting the flow into re-use and disposal options. This step may include, testing, shredding, disassembly and storage steps (Fleischmann, et al. 2000).

#### **2.1.3.5 Disposition**

*Disposition refers to the decision about what to do with returned product, which might include resale through secondary markets, recycle, remanufacture or transfer to a landfill.* (Rogers, Lambert, et al. 2002).

The disposition guidelines define where the product ultimately ends up. Companies that are at the front of supply chain should make disposition guidelines quickly, especially with products that lose value over time or have date codes. Rules for the products needs to be developed for disposition options with other members of the supply chain, as well as other managerial functions such as customer relationship management, product development and commercialization and supplier relationship management (Rogers, Lambert, et al. 2002).

There are several disposition activities such as cannibalization for parts, reprocessing, repair, recycling and more (Thierry, et al. 1995). Some of the most commonly presented by scholars that fall under re-processing:

- **Repair**

This is the process where the customer delivers the product back to the producer, often a product that has one or several of its features not working. This is to allow the producer the opportunity to repair the product, often with limited repair. The product then has a perceived lower value compared to a new product (Thierry, et al. 1995).

- **Refurbishing**

Where a product is brought up to a specified quality level this process. Could also be upgrading the technological aspect of the product. Often involves disassembling the

product, where the modules not up to the quality standard is replaced (Thierry, et al. 1995).

- **Remanufacturing**

This is a process where returned products are inspected and disassembled. Old and/or broken parts are replaced before the product is reassembled. This is to increase the quality of the product.

- **Cannibalization**

This is where a product is scavenged for one or more specific parts that are to be used for remanufacturing, repairs or the manufacturing of completely new products. Not to be misunderstood for recycling.

- **Recycling**

This is the process where a product is taken apart to scavenge usable resources. These resources can often be used for either making new products or delivering them for proper disposal. There is in recent time a big focus on the environment and recycling products is becoming more and more important both from the government and from customers perspective.

#### **2.1.3.6 Direct recovery**

Direct recovery can involve steps as direct re-use re-sale and re-distribution

If the quality is close to “as-good-as-new”, they can almost immediately be fed into the market almost immediately through this process, and sold as new goods or second hand goods at a mark down price (de Brito and Dekker 2003).

This is a process where some of the products may be re-used immediately without having to go through the production process again, albeit with some minor cleaning and limited repairs. Some examples of this could be pallets, containers and bottles. (Diaz, Alvarez, Gonzalez 2004)

#### **2.1.4 Why product returns management**

Product returns for manufacturers, distributors and retailers has always been looked at as an inconvenience, a source of potential customer dissatisfaction and cost center. For the customer the returns have often been seen as an unpleasant process, a necessary evil and, for the most, unavoidable. As long as products are sold, there will always be some returns. For many companies return management has been done as a necessity. However, many successful companies have realized that the returns process is not free, and that an effective strategy can

provide numerous benefits. Many companies are happy with minimizing the cost of managing and administrating the cost of product returns. However, product returns can be turned into a profit center if administered correctly. This requires that the company improve the recovery value of returns, obtain revenues from the reverse logistic activities and minimize cost of the return process. The reason why companies should do this is that more efficient product returns programs that can reduce variable costs, which results in improved margins (Stock, Speh og Shear 2006). Stock et al. (2006) describes six ways that reverse logistics can enhance profitability, improve revenues and reduce cost.

#### **2.1.4.1 Use of third parties:**

Since product returns management requires more than part-time effort and minimal resources, the use of third parties can sometimes be a better choice. This is especially true when the company has limited funds or experience, they lack expertise or the amount of products returned are low. There are several reasons why a company sometimes should outsource the product returns process. First, if the third party can do the job more quickly and accurately. Second, if the company experience few product returns and do not have dedicated return handling personnel. Finally, because third parties are often specialists in handling product returns, they can do the job more efficiently and effectively.

#### **2.1.4.2 Personnel and training**

The best companies in the return handling process are those with a full time manager responsible for the activity. They provide both formal and informal training, have standard operations procedures that are given to new and existing personnel, and are thoroughly going through their products and accordingly return processes. This all adds up to saved costs and more efficient product returns.

#### **2.1.4.3 Improved customer service and customer knowledge**

Effective product returns management often results in customer credits being issued more quickly and reduce the numbers of recurring problems, which lead to customer satisfaction and increased profitability. This also makes the customer more likely to engage in repeat purchasing with the same company. Return patterns is also an excellent source of buying habits and expectations of the customers.

#### **2.1.4.4 Efficient product returns as a marketable asset**

If a company has good product returns and reverse logistics operations they can be marketed to other companies and achieve revenues from selling the process or using the competency as a competitive advantage.

#### **2.1.4.5 Good communication**

Communication is needed for an efficient and effective product returns process. Both personnel and information systems will have to communicate rapidly and smooth. When looking into different reverse logistic activities it is obvious that these requires communication across different members of the supply chain, within the company, government bodies and customers.

#### **2.1.4.6 Effective inventory management and product dispositioning**

When this is done correctly, more value is generated from the disposition of the returned merchandise, since disposition have different cost and revenue implications. An efficient low-cost return process is not always the best strategy. Speed is a critical variable and managers need to remember that a low-cost supply chain is not always a fast supply chain. The longer it takes to retrieve and process a returned product, the more likely the economic viability is reduced.

## **2.2 Inventory Management**

Refers to the storing, ordering and use of a company's inventory, which often consists of raw materials, finished products and components. Inventory carries risk of damage, theft, spoilage and abundancy. Inventories should be insured and if not sold in time it has to be disposed of for a cost or simply destroyed. This is an important part to our master thesis since we try to measure the cost related to returned stock (Waters 2009).

### **2.2.1 Stock**

Waters (2009) describes stock as whenever materials are not used at the time they become available - and whenever there are breaks in the smooth flow of materials (Waters 2009). This also comprises the returned goods that well describes the break in the smooth flow when they are sent in the reverse flow. Inventory is a list of the things that are held in stock. Inventory management is the control of stock levels within a company. Holding stock is not free of charge (Waters 2009). Inventory carrying cost , is the cost associated with the quantity of

inventory stored, include a number of cost components and generally represent one of the highest costs of logistics (Lambert, The development of an inventory costing methodology: A study of the cost associated with holding inventory 1975). When it comes to calculating inventory carrying cost, one should include those costs that vary with the quantity of inventory and can be categorized in four different groups: capital cost, inventory service costs, storage space costs and inventory risk costs (Stock og Lambert, Strategic logistics management 2001, 196). (Waters 2009) Also describes that there are numerous costs that needs to be calculated appropriately and provides four categories that vary a bit from Stock and Lamberts categories. These are:

- Unit cost: This is the unit price charged by the supplier, or the cost of what it costs the company to acquire one unit of this product.
- Reorder cost: This is the cost associated with placing a repeat order of an item. There is many activities associated with this cost, prepping an order, delivery, receiving, correspondence, etc. To best estimate this cost, one divides the total annual cost of the purchasing department by the number of orders it sends out.
- Holding cost: Is the cost for holding a unit of an item over a unit period of time. Holding cost is associated cost of money, storage space, loss and obsolescence, handling, administration and insurance.
- Shortage cost: Is the cost that occurs when an item is needed but cannot be supplied from stock. Simplified this is the loss of profit from a sale. However, the effect of shortage is often much wider and can include more expensive suppliers being used, rescheduling and loss of customer satisfaction etc.

It is not always straightforward to get realistic figures of the inventory cost; shortage cost in particular can pose a particular problem. Shortage cost contains so many intangible factors that make them very hard to calculate such as loss of goodwill. This means that companies will often carry more stock than have to risk shortage costs (Waters 2009).

As a rule of thumb, the total cost of carrying cost over a year is 25 percent of the inventories value. This comes from Stocks and Lamberts review of different publications, regarding inventory management as seen in the table one the next side.

Author	Publication	Estimate of carrying costs as a percentage of inventory value
L. P. Alford and John R. Bangs (eds.)	<i>Production Handbook</i> (New York: Ronald Press, 1955), p. 397	25 %
George W. Aljian	<i>Purchasing Handbook</i> (New York: McGraw-Hill, 1958), p. 9-29.	12-34
Dean S. Ammer	<i>Materials Management</i> (Homewood, IL: Richard D. Irwin, 1962), p. 137.	20-25
Donald. J. Bowersox and David J. Closs	<i>Logistical Management</i> (New York: McGraw-Hill, 1996), pp. 254-58.	19.25*
Joseph L. Cavinato	<i>Purchasing and Materials Management</i> (St. Paul, MN: West Publishing, 1984), p.284	25
John J. Coyle, Edward J. Bardi, and C. John Langley Jr.	<i>The Management of Business Logistics</i> , 6th ed. (St. Paul, MN: West Publishing, 1996), pp. 200-7.	25
Gordon T. Crook	"Inventory Management Takes Teamwork," <i>Purchasing</i> , March 26, 1962, p. 70.	25
Thomas W. Hall	Inventory Carrying Cost: A Case Study, <i>Purchasing</i> , March 25, 1962, p. 70.	20.4
J. L. Heskett, N. A. Glaskowsky Jr., and R. M. Ivie	<i>Business Logistics</i> , 2nd ed. (New York: Ronald Press, 1973), p. 20.	28.7
James C. Johnson, Donald D. Wood, Daniel L. Wardlow, and Paul R. Murphy Jr.	<i>Contemporary Logistics</i> , 7th ed. (Upper Saddle River, NJ: Prentice Hall, 1999), pp. 302-4.	25
John F. Magee	"The Logistics of Distribution," <i>Harvard Business Review July-August 1960</i> , p. 99.	20-35
Benjamin Melnitsky	<i>Management of Industrial Inventory</i> (Conover-Mast Publication, 1951) p. 11.	25
Thomas M. Whitlin	<i>The Theory of Inventory Management</i> (Princeton, NJ: Princeton University Press, 1957), p. 20.	25

\*19.25% is given as an average, with a range of 9% to 50%.

Table 2: Estimates of inventory carrying costs. Source: (Stock og Lambert, *Strategic logistics management 2001*, 195)

The publications in the table range from 1951 to 1999 and shows that most of the carrying costs is 25 percent. However, these are fairly old publication and the interest rate has fluctuated between 3 percent to 20 percent since that time. Therefore, each company should determine its own logistics cost and strive to minimize the total of these (Stock og Lambert 2001, 194).

## 2.2.2 Warehouse

As mentioned in the section above, stock appear in the supply chain where the flow of material is interrupted. A warehouse is any location where the stocks of material is held throughout the supply chain (Waters 2009). In the reverse logistic process, warehousing involves a number of elements, including layout and design, facility location, salvage and scrap disposal and use of materials handling equipment (J. R. Stock 1998, 31).

## 3 Data Collection

This chapter provides information about our data collection methods, and what sources we have for primary and secondary data.

### 3.1 Primary

According to (Sachdeva 2008) primary data, is data collected by the researchers through different kinds of interaction with the source of the information. These methods include interviews, direct observations and surveys. This allows the researcher access to original and unedited data. Researchers often choose in this stage whether they wish to use a qualitative or quantitative approach when it comes to collecting the data. (Saunders, Lewis og Thornhill 2009) Categorized these interviews as unstructured, semi-structured and structured.

Unstructured and semi-structured interviews is often used for qualitative research as they allow the interviewee to answer the questions in their own way, while structured interviews often come with predetermined answer and is thus considered a quantitative approach.

Our primary data collection has been done through interviews, done over email or the phone with key personnel at Elektroimportøren. We have also used their webpage that are publicly available to seek out information of their returns process (Elektroimportøren 2017).

### 3.2 Secondary

(Sachdeva 2008) States that secondary sources of data, is data from primary sources that have been edited or been previously collected and utilized in research. Secondary data often takes the role of combining previously research data with new information from primary sources to explain the findings of the researcher. It can also be used as a reference base from which it is possible to compare the accuracy and validity of the primary data collected. In this research, we have collected secondary data from the company in the form of sales reports, return reports, complaint reports, picking error reports and background information regarding the company. These reports have been generated in the ERP system of the company. The company uses VISMA ERP-Software, which is a cloud-based solution which offers different modules such as accounting, purchasing, logistics and more. The company uses barcodes as the most used method for collecting information about the products. In some cases, manual entry of data is required, and the manual entry is mostly revolved around receiving returned products. We have also acquired a significant amount of secondary data through scientific articles published in different academic journals, databases and relevant books. Our dataset



received from Elektroimportøren goes from the first of May 2015 till the fifth of February 2018.

## 4 Methodology

This chapter will explain how we approach our case study. It contains our research method, data collection, research design and the credibility of the research, as well as the method we used to do our calculations.

### 4.1 Research Method

To first determine what kind of research we will conduct, we need to distinguish between quantitative and qualitative research. A quantitative research method is based on statistical and numerical data and is a method used for quantifying a problem. It is a convenient method for managing large quantities of data that can easily be displayed in tables and figures.

Quantitative data is often collected using methods such as different types of surveys, interviews, systematic observations and extraction of numerical data. The interviews is often set up in a way, which lets the interviewee answer in closed-ended answers, typically yes or no. Since quantitative techniques cannot always be used, we also have the qualitative research approach.

According to (Johnson and Onwuegbuzie 2004) some of the strengths of using quantitative research is;

- Easier to test and validate already existing theories on how certain phenomena occur.
- Makes it possible to test hypotheses that have been constructed before data has been collected.
- Data analysis is often less time consuming if using software for calculations.
- Often provides researchers with higher credibility.
- Very useful when studying large sample sizes.

Some of the weaknesses of quantitative research is;

- The knowledge produced by the research may be too abstract or too general for it to be applied in specific contexts.
- The researchers' categories and theories that are used in the research may not reflect the understanding of the local constituencies.

A qualitative research is based on the interpretation of the researchers and is primarily exploratory research. Is often conducted through different types of interviews, where the goal is to ask open ended question which requires more thought than a simple yes or no answer. It

is a method often used for revealing and understanding the underlying motives, reasons and opinions of the interviewee. Whereas quantitative research is often structured in a strict way, qualitative often takes the approach of no or very little structure, enabling the interviewee to behave as normally as possible where the interviewer often takes a passive observational role. Other methods often used for qualitative research includes focus groups which is often done as group interviews, individual interviews and doing observations on a sample group. Some of the strengths of using the qualitative approach is according to (Johnson and Onwuegbuzie 2004);

- It is often very useful for describing complex phenomena.
- Provides understanding and description of the personal experience of the people being interviewed.
- Provides good opportunities to explain complex phenomena.
- Provides information regarding specific cases.

Some of the weaknesses presented by (Johnson and Onwuegbuzie 2004) is as follows;

- The results found in the research may not be applicable for generalization to other people or different settings.
- It is more difficult to test hypotheses and theories.
- The analysis of the data is often more time consuming.
- It may provide you with lower credibility with administrators.
- The result can more easily be influenced by the personal thoughts and ideas of the researchers.

A combination of these two methods as mentioned above is called a mixed research approach and is defined by (Johnson and Onwuegbuzie 2004) *as the class of research where the researcher mixes or combines quantitative and qualitative research techniques, methods, approaches, concepts or languages into a single study*. This is not a limiting form of research, but an expansive and creative form of research. (Johnson and Onwuegbuzie 2004). Using mixed methods research is more challenging than conducting studies limited to single methods. However, by using this kind of research method the researcher can address broader and or more complicated research questions than case studies alone (Yin 2009, 64). Yin defines a case study *as an empirical inquiry that investigates a contemporary phenomenon in depth and within its real-life context, especially when the boundaries between phenomenon and context are not clearly evident*. (p.18). another newer definition is that *case study*

*research is an inquiry that describes understanding, predicting and/or controlling the individual* (Woodside 2010, 1)

For our thesis, we will use the mixed methodology research of a case study. Since we have real world empirical data, we can use the quantitative method to express numerical quantifiable terms. We can also use the qualitative results to get a deeper understanding of relationships and complex interactions of the reverse logistics process for a company like Elektroimportøren, which may also be applied to the entire industry.

## **4.2 Induction, deduction and abduction**

When it comes to describing the relationship between theory and empirical data, there are three approaches. Induction, deduction and abduction. Both induction and abduction starts out with empirical observations before any theoretical framework is found or indicated in the research process. In an inductive process, the theoretical framework is missing completely, while abductive processes can also start without the theoretical framework. Deductive processes on the other hand, always start with a theoretical framework: The hypothesis or the propositions that should be further evaluated are already given prior to any empirical research (Kovács and Spens 2005). The aim of the inductive and abductive approach is both to develop theory, while deductive approach is testing or evaluating theory (Arlbjørn and Halldórsson 2002). Given that our thesis is based on theory and empirical data requested from Elektroimportøren, it follows a deductive process as the questions are connected to the main objectives of the study.

## **4.3 Research Design**

When it comes to the purpose of our research, we will choose exploratory research. Exploratory research tries to reveal why something is being done. It provides depth and insight into a little-known phenomenon (Ellram 1996). Exploratory research focuses on gaining insight and familiarize ourselves with the area of our subject (Anagnostopoulos 2017). This lines up well with our case study and will give suggestions to further research. Another approach that could be suitable for our research would be descriptive. Descriptive research can both serve qualitative and quantitative methods. Description include the nature of the phenomenon (how many, how much), as well as establishing who is performing or participating in the activity (Ellram 1996). Descriptive research focus on measure the

characteristic of the issue or particular problem (Anagnostopoulos 2017). Given the data provided by Elektroimportøren, exploratory as mentioned before seems to be the best approach.

## **4.4 Research Quality**

(Guba 1981) Provides with four aspects that are important when considering the trustworthiness of our findings. These aspects are important for us to establish connections to as we present our research. The aspects mentioned by Guba are credibility, transferability, dependability and confirmability.

### **4.4.1 Credibility**

(Rodwell and Byers 1997) Refers to an activity called triangulation. Triangulation attempts to increase the possibility of produced credible findings and is done through using multiple sources of data, different participants and different methods to ensure consistent data. For our research, we have used interviews with key personnel in the company to validate the secondary data we have been given access to. This has been done through semi-structured and unstructured interviews done over the phone or email.

### **4.4.2 Transferability**

Transferability is a term that allows the researchers to reflect on whether these findings can be applicable in other situations or contexts. It is however difficult to demonstrate that the results and findings of your research can be applied to other scenarios as there are specifics that may only be applicable in scenario researched (Rodwell and Byers 1997), (Shenton 2004).

The interpretation of the research done in this thesis should be carefully analyzed before being considered to be applicable to other contexts. While this thesis is aimed at a specific company in a specific industry, it is possible that the work done here could be applicable in other scenarios where companies operate online and offer product returns.

### **4.4.3 Dependability**

(Rodwell and Byers 1997) Argues that dependability is something that needs to be proven before the appropriateness of the methodological shift can occur throughout the research process. (Shenton 2004) Explained dependability as necessary through the research progress, and that the research progress should be detailed in such a way that the readers can understand

the methods used. Shenton also argued that dependability is the ability for future researchers to effectively replicate the research found in that particular study.

As much of our data is second-hand data received directly from the company we assume that future researchers will find similar results as reported here. We have also described the process used for our calculations and findings which, should make it possible to replicate it in further research for a case in a similar context.

#### **4.4.4 Confirmability**

(Rodwell and Byers 1997) Relates confirmability to the connection between data management and the data analysis to establish a connection between the study results and the data used in the study. In order to achieve this, (Shenton 2004) argues the importance of a researcher's ability to demonstrate that the findings presented in the study comes from the data studied and not the personal opinion of the researcher. Triangulation plays an important role to confirm that the research presented here is valid and not of the researcher's personal opinion.

### **4.5 Calculations**

For our calculations, we first had to take an in-depth view of the dataset we had received. This was done to search for potential errors and noise in the dataset that were incorrect and would skew the data sample. We first start in the datasheet looking at returns and complaints and started removing rows in the Excel spreadsheet that had a cost price of zero. We proceeded to remove rows where the sales price was either zero or negative, before analyzing the remaining product rows where we would divide the unit sales price with the unit cost price in order to see the relationship between these. We proceeded with removing several rows where we would see that the cost price were several thousand percent higher than the sales price. We also removed rows where the sales price were abnormally high compared to the cost and verified this with Elektroimportøren that there were errors in the data sheet. We went from 39096 rows to 31751 during the clean-up process of the datasheet, thus removing 18.78 percent of the data. This left us with:

- 7335 Total orders that contained either return, complaint or both.
- 106 containing both return and complaint.
- 6368 Orders containing returns.
- 1073 Orders containing complaints.

After discussing the large amount of noise in the dataset with Elektroimportøren, we found the reason to be a combination of user error at the point of data entry, but also some compatibility problems with their ERP Software VISMA. In order to accommodate for this 18.78 percent reduction in data we will do a markup of the costs by 18.78 percent to attempt to make it as representative as possible.

After cleaning up the dataset, we proceed with interviewing key personnel at Elektroimportøren again in order to visualize their return management and what processes they encounter. We were told by a company representative that all products that were filed as complaints with a sales value below 200 NOK was to be deposited at the appropriate disposal facilities. This resulted in customers who called their customer service being given the option to either send it back to Elektroimportøren or preferably throw it away. The company uses Posten as the transportation company and with Norgespakken their fees ranging from 79 NOK to 139 NOK per shipment depending on size. Elektroimportøren informed us that they operate with an average transportation cost of 100 NOK per shipment. This allows Elektroimportøren to save the transport cost from the customer and back to their warehouse for products with a sales price below 200 NOK. They do however have to take the cost of it into account, as they need to send a new product back to the customer. Because products under the sales value of 200 NOK is disposed of, it is counted as a direct loss as the manufacturer for these products does not compensate Elektroimportøren. We have chosen to calculate the transportation cost for complaints as 100 NOK per product, rather than 100 NOK per customer order. This is because for a product to be qualified for complaints it has to have a fault within it that has occurred due to a weakness of the product. We find it unreasonable to assume that these errors or faults occur at the same time as other products within the same customer order, as it is likely that the fault only occurs with the specific product. We therefore assume that these complaint products are returned at different times.

For products with a sales price less than 200 NOK, we calculate the costs as:

- Loss in cost price value: We multiply the cost price (cost of acquiring the product) of the products with the amount they have sold.
- Transport cost for new products back to customer: We multiply the average transport fee, which is 100 NOK with the amount of complaint products under the sales price of 200 NOK. This is in order for Elektroimportøren to replace the faulty product.

- Total cost for complaint products under 200 NOK sales price: This is calculated by adding together “Loss in cost price value” and “Transport cost for new product back to customer”.
- Sales Price: This is calculated by multiplying the sales price for all the complaint products with the amount returned.
- Lost profit: This is calculated by subtracting the cost price value from the sales price (“Sales Price” – “Cost Price”). This indicates the profit they also lose by replacing a complaint product under the sales price of 200 NOK, as these are not eligible for compensation.
- Total cost incl. Loss of profit: This is calculated by adding “Total Cost for complaint products under 200 NOK sales price” with “Lost Profit.”

For products that has a sales price equal or greater than 200 NOK from external manufacturers we calculated the costs as:

- Cost Price: Cost of acquiring the product multiplied by the amount of the specific product.
- Sales Price: Sales price of the product multiplied to the quantity of that product sold.
- Potential loss of profit: This is calculated by subtracting the cost price from the sales price; Sales Price – cost Price and is a worst-case scenario cost as it represents the shortage cost if they encounter a stock out after replacing a faulty product.
- Transport cost from customer to warehouse: This is the price for transporting the faulty product from the customer and back to Elektroimportøren. Calculated by multiplying the average transport cost with the number of products returned.
- Transport cost from warehouse to customer: This is the price for transporting the new product to the customer. Calculated by multiplying the average transport cost with the number of products returned.
- Total cost (transport, loss of profit): This is calculated by adding “Potential loss of profit” with “Transport Cost from customer to warehouse” and “Transport cost from warehouse to customer.”



For the remaining products that have been filed as complaints, over the sales value of 200 NOK, Elektroimportøren sends a compensation request to the manufacturer, which in most cases cover the cost of acquiring the specific product. It is however important to note that Elektroimportøren also operates with their own unique brands which they either manufacture themselves directly or collaborate with other manufacturers. In this case, the compensation they would normally request would be directed to themselves and the cost of the products here would therefore be considered a direct loss. Elektroimportøren states that roughly 28 percent of their total sales comes from their private labels, but they lack data about how much of their complaints are private labels. After discussing it with Elektroimportøren, we have found it reasonable to assume that 28 percent of their complaints to be private labels and is thus calculated in a way where the cost of these 28 percent is not compensated by any manufacturer, but is rather considered a loss. We have also added the opportunity cost for private labels as the product that is sent to the customer as a replacement could be sold to another customer for the full retail price.

The costs for private label complaints with a sales price equal or greater than 200 NOK we calculated as:

- Cost price for private labels: Calculated as the cost of acquiring the product multiplied by the quantity of product being returned for complaint reasons.
- Loss in cost price: Is the same as above but is here considered a loss as this is not eligible for compensation by any external manufacturer.
- Sales price for private labels: This is calculated by multiplying the sales price of the products with the quantity of the same products.
- Potential loss of profit: This is calculated by subtracting the cost of a product from the sales price; “Sales price for private labels” – “Cost price for private labels”. This is considered an opportunity cost, as they are not able to sell the new product they sent to the customer for full price and thus miss the profit it would generate.
- Transport cost from customer to warehouse: This is calculated by multiplying the amount of complaint products with the average cost of transport.
- Transport cost from warehouse to customer: This is calculated by multiplying the amount of complaint products with the average cost of transport.

For the total cost for complaints Elektroimportøren first of May 2015 – fifth of February 2018 is calculated as:

- “Total cost incl. Loss of profit for products with sales price less than 200 NOK” + “Total cost (Transport, loss of profit) for products with a minimum sales price of NOK 200 (External manufacturer)” + “Total cost for private labels (Incl. Loss in cost price, loss of profit and transportation cost).”

Elektroimportøren offers their customers 60 days of open purchase with free return, meaning their customers are able to return the products they bought within 60 days at no additional cost. The products that are returned are either sold as a new product if it is unopened and in good shape, while opened products are to be sold as a second-hand product. New products are placed back into rotation and can be resold whenever a customer wishes to buy that particular product. However, the second-hand products are transported to their largest warehouse where they have a section designated for second hand products. As estimation by Elektroimportøren is that 80 percent of their returned products are in such a condition that they can be sold as new products, while the remaining 20 percent is sold at this particular warehouse at a discounted price. Elektroimportøren has no specific data on the second-hand product prices but in a general setting they assume the products are discounted at least 50 percent of the retail price before being put out in the store, however they sell the products from anywhere between 30 to 50 percent of the retail price. In order to reduce second hand inventory, they have created incentives for the stores to sell these products as the stores receive the products free and whatever price they sell it for is direct profit for the store while the wholesaler (Elektroimportøren Purchasing Department) covers the cost of the product. We therefore looked at the scenario where 80 percent of the goods returned were to be sold as new products, while the remaining 20 percent were to be sold as second-hand products. For this calculation, we also take into consideration the transport cost for the product from the customer back to the warehouse.

Warehousing cost is another important factor to look at. Elektroimportøren had no estimate of how the products returned affected their warehousing cost. By doing a literature research seen in section 2.2.2 of this thesis, we decided to go with a holding cost of 25 percent of stocks annually. We have calculated a rough estimate of their carrying cost including reorder cost, which in our case will be the transportation cost. This warehousing cost is calculated per year,

from May 2015 until February 2018, with the assumption that they are resold within one month.

The warehousing costs are calculated as:

- Unit cost: This is the cost of acquiring the specific product multiplied with quantity returned within the given time period.
- Reorder cost: We calculate this as the return transport cost which is the average transport cost (100 NOK) multiplied by the amount of orders returned within the given time period.
- Holding cost (25% per year): We calculated this as 25% of the unit cost and then divided it on the months in the year so get it down to a one-month period.

We proceeded to create pivot charts to see the monthly trends of return from May 2015 and until the beginning of February 2018 to give us a clearer view of the returns and to see how it is evolving.

## 5 Results

In this chapter will present the results that we found when trying to answer our research question “What are the key cost drivers for Elektroimportøren and is it possible to identify these costs in a business process map detailing their return processes?”

### 5.1 The identification of Elektroimportørens returns process

By interviewing key personnel at Elektroimportøren and looking on their webpage, we have been able to identify their product return process. This is presented through Business Process Model Notation 2.0 (BPMN) in the figure on the next page. The legend of the figure is provided, and a step identification number is tied to each process to help explain, due to some processes are similar although different in the flow of the figure.

The return process starts at step 1, where the customer through either e-mail, phone or “my page” on the internet request a product return. In step 2, there is an exclusive gateway, which mean that the product returns must be either a return or a complaint. If the customer wish to complain, Elektroimportøren differentiates the product by a sales price lower than 200 NOK or equal and higher, seen in another exclusive gateway. In step 4, Elektroimportøren handles the complaint and follows up with a parallel gateway (step 5), which means both tasks are handled simultaneously. Step 9 shows that the task is finished when both tasks before are handled. In step 11, we have used a time event. This is because Elektroimportøren must wait for the product to arrive their main warehouse for further handling. Step 16 is an exclusive gateway that leads to either a parallel gateway or another task, respectively step 17 and 22. Following the private product path from step 15 to 17, we can see that we can start two tasks simultaneously. This is because Elektroimportørens disposition of the product is not dependent on the new product being shipped to the customer, step 18 and 19. However, they must both be finished before the process is finished, seen in step 20. We find that step 19, 37 and 59 all have a sub process. This is because the disposal process is reliant on the condition of the product and the type. Our thesis does not focus on this process and it is therefore collapsed into this disposal process. From the start point, the returns process of Elektroimportøren can end at twelve different end events. This is depending on return or complaint and the state of the product, if it is a private label or external.

BPMN 2.0  
of Elektroimportøren returns process

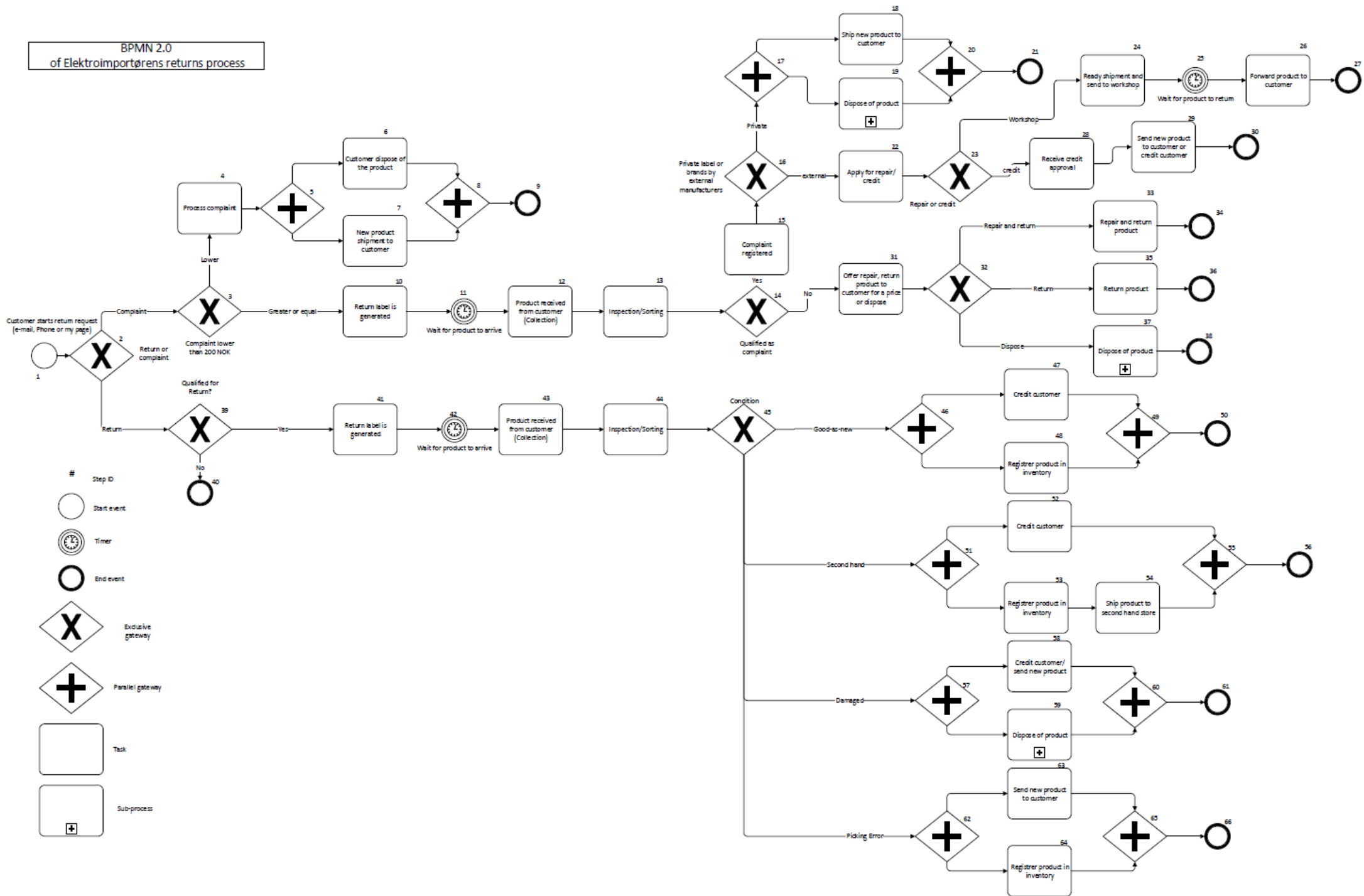

Figure 4: BPMN of Elektroimportøren returns process

## 5.2 Cost results from complaint calculations

The following table 3 shows a breakdown of the costs for complaint products with a sales price under 200 NOK. As products under 200 NOK is thrown away, we calculate the loss in cost price as the price for the product that the company buys it for and the direct loss they experience when throwing it away. Transport cost for new product back to the customer is the only transportation used for products under 200 NOK and contains the replacement product for the customers. Sales price is the sales price of the same unit and we have calculated the lost profit as an opportunity cost, as ideally the company would want to sell the replacement product for the full price. As any external manufacturer does not compensate these costs, it is considered a direct loss. This results in the total cost including Loss of profit for products under the sales value of 200 NOK.

Complaints products with a sales price less than 200 NOK	
Loss in Cost Price value	355 987.56
Transport Cost for new product back to customer	109 396.38
<b>Total cost for complaint products under 200 NOK sales price</b>	<b>465 383.94</b>
Sales price	454 531.55
Lost profit	117 050.56
<b>Total Cost incl. Loss of profit</b>	<b>582 434.50</b>

Table 3: Complaints products with a sales price less than 200 NOK

Table 4 shows the costs for complaint products with a sales value of minimum 200 NOK from an external manufacturer. In this table you will find the cost price for the product, the sales price that it is sold for and the potential loss of profit. Complaint products with a sales value of 200 NOK and higher is eligible for a compensation request towards the manufacturer and the cost price is thus not a direct cost. We have included the loss of profit here as well as the company could potentially experience a stock out where it replaces the product for their customer while a new customer wishes to buy the same product. In this scenario, the manufacturer would not compensate the loss of profit, but only the cost of acquiring the product. The transport cost here is calculated for the complaint product to be sent from the customer and back to Elektroimportøren, and for Elektroimportøren to send a new replacement product back to the customer.

Complaints for products with a sales price of minimum 200 NOK - External Manufacturer	
Cost Price	1 847 447.09
Sales Price	2 755 864.15
<b>Potential loss of profit</b>	<b>908 417.06</b>
Transport cost from customer to warehouse	237 921.09
Transport cost from warehouse to customers	237 921.09
<b>Total cost (Transport, loss of profit)</b>	<b>1 384 259.24</b>

Table 4: Complaints for products with a sales price of minimum 200 NOK - External Manufacturer

For table 5 we have calculated the cost for complaint products with a minimum sales value of 200 NOK for internal manufacturing, or private labels. This includes the cost of the product, the sales price, the loss of profit and transportation back and forth from the customer. As these are Elektroimportørens own brands they do not receive any compensation for the faulty products and thus must cover it themselves. This includes the direct cost of the product, meaning the manufacturing cost and the cost of getting it to their warehouse. The loss of profit comes from the need to send out a replacement product and being unable to charge full retail price for the replacement product. Transport is to receive the product from the customer and to send the replacement product to the customer. This gives us a view of the costs for private label products being qualified for complaints.

<b>Complaints for products with a sales price of minimum 200 NOK - Private Labels</b>	
Estimated that 28% of all complaints are private labels such as NAMRON.	
Cost price for Private Labels	718 451.65
<b>Loss in cost price</b>	<b>718 451.65</b>
Sales price for Private Labels	1 071 724.95
<b>Potential loss of profit</b>	<b>353 273.30</b>
Transport cost from customer to warehouse	92 524.87
Transport cost from warehouse to customer	92 524.87
<b>Total cost for private labels (Incl. Loss in in cost price, loss of profit and transportation cost)</b>	<b>1 256 774.69</b>

Table 5: Complaints for products with a sales price of minimum 200 NOK - Private Labels

We have then put all these costs together to get a full view of the cost picture for Elektroimportøren in table 6, showing the costs for products below the sales price threshold of 200 NOK and the cost of complaint products above the threshold, both internal and external manufacturing.

<b>Total cost for complaints for Elektroimportøren May 2015 - February 2018</b>	
Total cost incl. Loss of Profit for products with a sales price less than 200 NOK	582 434.50
Total cost (Transport, loss of profit) for products with a minimum sales price of NOK 200 - External manufacturer	1 384 259.24
Total cost for private labels (Incl. Loss in cost price, loss of profit and transportation cost)	1 256 774.69
<b>Total cost</b>	<b>3 223 468.43</b>

Table 6: Total Cost for complaints for Elektroimportøren May 2015 - February 2018

### 5.3 Cost results from return calculations

Table 7 shows the cost of the returned products experienced by Elektroimportøren in the time period May 2015 – early February 2018. An estimation of 80 percent of the returned products could be counted as new products and could therefore be sold for retail price, while the remaining 20 percent were to be sold as second-hand products.

Elektroimportøren estimates that they are shaving off 50 percent from the retail price, but the products go from anywhere from 50 percent of retail price to 30 percent of the retail price. To provide an overview of the costs we have therefore calculated 10 percent of the returned products as being sold for 50 percent of the retail price and the last 10 percent as

30 percent of the retail price. The table shows the transport costs for the products from the customer and back to the warehouse and the profit the company should expect on both the returned products that are as good as new and the second-hand products.

Cost of products		New sales price			Transport Cost	Profit
		100 %	50 %	30 %		
80% of products sold as new	11 264 756.87	14 447 568.46			509 440.00	2 673 371.59
10% of products sold as used	1 408 094.61		902 973.03		63 680.00	-568 801.58
10% of products sold as used	1 408 094.61			541 783.82	63 680.00	-929 990.79
					<b>Total profit</b>	<b>1 174 579.22</b>

Table 7: Sale of returned products as new vs. Second-hand

For table 8 we are looking at the warehousing and holding cost of the returned products. Therefore, the unit cost is only 20 percent of the total returned, as the remaining 80 percent is considered as a new product and thus taken into normal sales rotation. These tables show the evolution of the warehousing costs for the returned products from May 2015 and until the first five days of February 2018. Reorder cost is considered to be the transportation cost of returning the product from the customer and back to Elektroimportøren. Holding cost is estimated to be 25 percent of the unit cost.

If returned products are sold in 1 month			
Warehousing costs from May 2015		Warehousing costs 2016	
Unit cost	65 102.19	Unit cost	42 534.26
Reorder cost	106 902.00	Reorder cost	166 885.90
Holding cost (25% per year)	16 275.55	Holding cost (25% per year)	10 633.56
<b>Total holding cost 2015</b>	<b>123 177.55</b>	<b>Total holding cost 2016</b>	<b>177 519.46</b>
Warehousing costs 2017		Warehousing costs till February 2018	
Unit cost	110 619.40	Unit cost	16 426.59
Reorder cost	408 246.86	Reorder cost	74 356.28
Holding cost (25% per year)	27 654.85	Holding cost (25% per year)	4 106.65
<b>Total holding cost 2017</b>	<b>435 901.71</b>	<b>Total holding cost 2018</b>	<b>78 462.93</b>

Table 8: Warehousing costs annually for returned products if sold in 1 month

Figure 5, 6 and 7 shows the trend of the total returns for Elektroimportøren. Table 5, Total Returns 2015 starts in May as that were data point we received and we combined 2017 with 2018 in table 7 as we only got data up to the start of February 2018. You will see the dates on the X-axis and the total sales price of the returned goods on Y-axis.



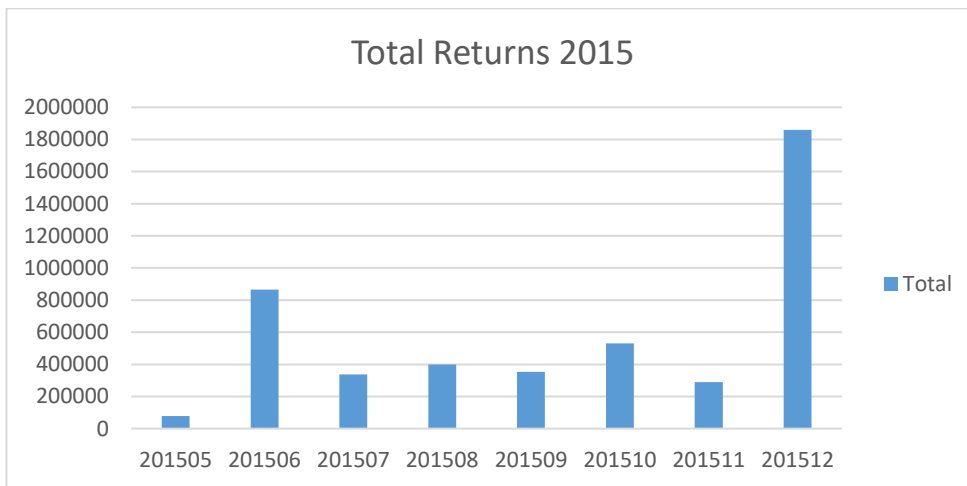

Figure 5: Total Returns 2015

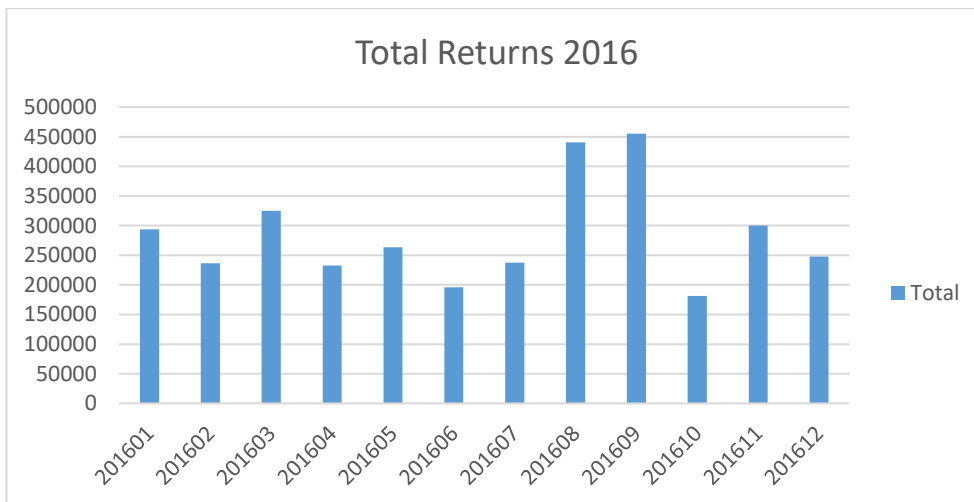

Figure 6: Total Returns 2016

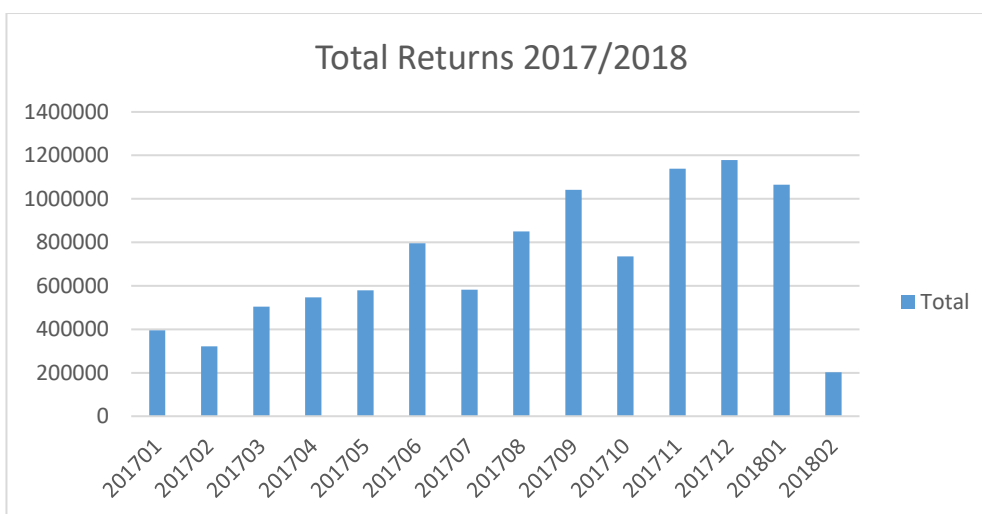

Figure 7: Total Returns 2017/2018

In table 9, we created a forecast using return volumes from 2017 and January 2018 using a confidence interval of 95 percent. Shown in the table you will see the forecasted value,

lower confidence level and upper confidence level. The figures presented here is the total return volume measured in total sales returned.

Timeline	Values	Forecast	Lower Confidence Bound	Upper Confidence Bound
01.01.2017	395854.7802			
01.02.2017	322067.7533			
01.03.2017	503894.5263			
01.04.2017	547162.9088			
01.05.2017	579039.1848			
01.06.2017	795297.7259			
01.07.2017	582304.1856			
01.08.2017	850309.2457			
01.09.2017	1041698.783			
01.10.2017	735011.7447			
01.11.2017	1138555.107			
01.12.2017	1179204.675			
01.01.2018	1065153.652	1065153.652	1065153.65	1065153.65
01.02.2018		1344814.775	1151718.78	1537910.77
01.03.2018		1392200.846	1198122.46	1586279.23
01.04.2018		1265307.292	1070232.07	1460382.52
01.05.2018		1545096.189	1270342.30	1819850.08
01.06.2018		1592482.26	1316995.44	1867969.08
01.07.2018		1465588.706	1189356.80	1741820.61
01.08.2018		1745377.603	1407792.18	2082963.03
01.09.2018		1792763.674	1454546.57	2130980.78
01.10.2018		1665870.121	1327010.69	2004729.55
01.11.2018		1945659.018	1554876.80	2336441.23
01.12.2018		1993045.088	1601686.04	2384404.13
01.01.2019		1866151.535	1474206.00	2258097.07

Table 9 Forecast values for returns 2018/January 2019

Figure 8 is a visualization of table 9 showing the forecast of returns based on historic data from 2017 and January 2018 and shows the forecast one year in the future.

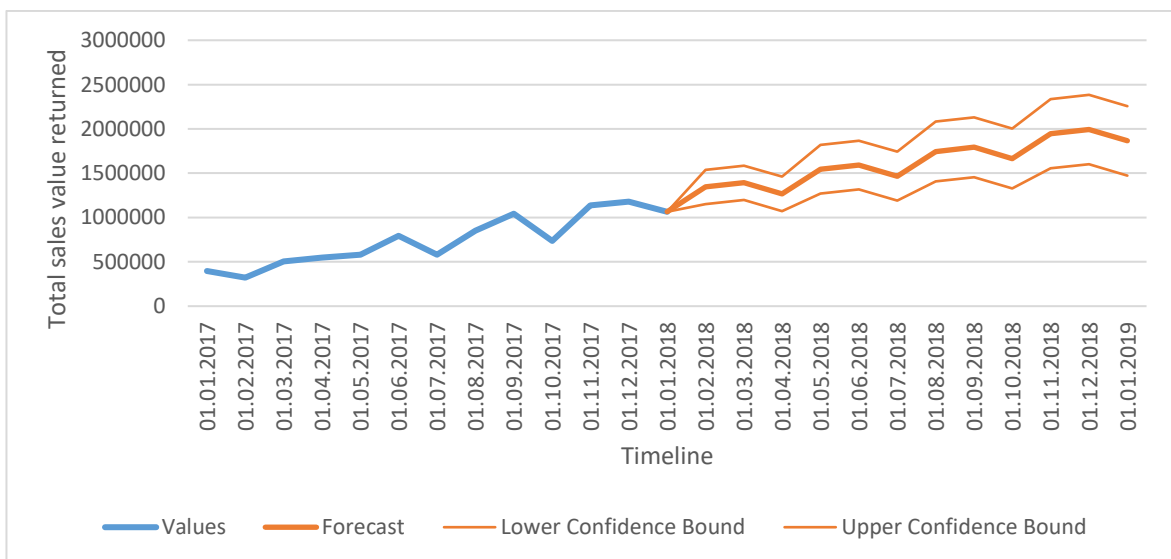

Figure 8 Visualization of forecast for returns 2018/January 2019

## 6 Discussion

In this chapter we interpret the complaint and return processes of our business process model notation and discuss it based on our research question “What are the key cost drivers for Elektroimportøren return processes and is it possible to identify these costs in a business process model notation? “ We also suggests possible actions to increase efficiency in the product returns process.

### 6.1 Interpreting the business process model and the costs occurring for complaints

Given the result of our business process model notation (BPMN), we were able to map the return processes for Elektroimportøren and were able to identify several costs that appear throughout the processes. We will start by discussing the costs that appear in the complaint processes. As previously mentioned the entire process starts when a customer contacts Elektroimportøren to report a faulty product. From the results of the return process model, the first few steps include some identified but not quantifiable administrative costs that they cover currently through excess capacity. Therefore, these costs are not taken into considerations in our results, but will be an important factor to look into for the future because of the growing return trends as seen in figure 5, 6 and 7. Our first quantifiable cost occurs after step 5 in complaints, where step 6 and 7 occurs at the same time. In step 6, the customer is asked to dispose of the product resulting in a loss for Elektroimportøren for the cost value of that product; Elektroimportøren does not want to have products under the sales value of 200 NOK to be returned to them. They find the return process for these products to be costlier than to trust their customers and offer a new product in compensation as an act of goodwill. In step 7, the costs are identified as the transport cost for replacing the faulty product with a new one and the loss of profit Elektroimportøren would be able to generate if they were to sell the replacement product for a retail price, which is displayed in our calculations in table 3. In table 3, we found the key cost drivers for complaint product under 200 NOK to be the loss of value when disposing of the product, the loss of profit that you would have generated if you could sell the replacement product for a retail price and the transportation cost of returning a new product to the customer.

If the product has a sales value of 200 NOK or greater it must be returned to Elektroimportøren to see if it qualifies as a complaint product. In this scenario, the first possible cost appears in step 10 where Elektroimportøren generates the return label for the product, which generates an average transportation cost of 100 NOK per return shipment. In step 13 and 14 handling costs occur, but that has not been calculated since Elektroimportøren currently uses excess capacity to handle this, but as mentioned above, the capacity need will increase, and extra shipments might possibly be required. In step 14, Elektroimportøren decides if the received product qualifies as a complaint. If it does not qualify for a complaint, the customer receives some options from Elektroimportøren, with a potential bill sent to the customer depending on the customer's choice. If for instance the customer chooses to have Elektroimportøren dispose of the product, it will generate a cost to handle the disposal of the product if the process exceeds current capacity levels.

If, however, the product qualifies as a complaint some different costs occur. When the product qualifies for return, Elektroimportøren must separate the process depending on if it is a private label or another brand from an external manufacturer. If the product comes from an external manufacturer the first cost that are identified are some handlings costs that currently are within available capacity, this is done through generating a repair order or credit request in step 22. If credit request is the approved option by the manufacturer because it is not profitable to repair the product, Elektroimportøren sends a new product to the customer generating transportation cost in step 29. If the product is eligible for repair there are transportation costs in step 24, 25 and 26. We find it reasonable to assume that the manufacturer handles the transportation cost between themselves and Elektroimportøren in step 24 and 25, while Elektroimportøren handles the cost between them and their customer in step 26. The cost mentioned here are shown in table 4 where we found the key cost drivers to be the transportation, while "potential loss of profit" is something to take into consideration as it is indicating a potential shortage cost if they were to replace a product and miss a following sale due to an empty inventory. We find it reasonable to assume that Elektroimportøren bears no cost for the faulty complaint product as the manufacturer is expected to compensate them for their cost in acquiring the product; however, there is always the risk of a stock-out generating a shortage cost.

For private labels products, Elektroimportøren starts two simultaneous processes in step 18 and 19. In step 18 Elektroimportøren generates transportation cost, as they have to

transport the new product to the customer. The loss of profit cost also occurs here as the product they sent out as a replacement could be sold for a full retail price generating profit for them. In step 19, they dispose of the returned product, which could be to dispose of it or to cannibalize it for parts. Cannibalization could help them recover some profits from faulty products. The cost for loss of profit also occurs in step 19, as Elektroimportøren is not able to request compensation from external manufacturers for the private label product, as they are the manufacturer of it. The total costs for private labels are showing in table 5 and we find the key cost drivers here to be the loss in value of the product, loss of profit and transportation costs.

This shows the total costs for complaint at Elektroimportøren in table 6. As we can see from the tables, the largest possible cost is from external manufacturers with a sales price of 200 NOK or greater. However, it is very important to realize that for this cost to be fully realized, they need to experience a shortage cost for their profit on every return, which is highly unlikely. The second largest cost comes from private labels with a sales price of 200 NOK or greater and while these costs are more likely to happen there are actions that can be taken to reduce the cost of this. We have referenced in section 2.1.3.5 of several activities that can be used in the disposition phase that can recapture value from the product. One example of this is for cannibalization of usable parts that can be used in remanufacturing later.

For products with a sales price below 200 NOK, there is possibility to reduce this cost through negotiations and contracts with their external suppliers to come to agreement on compensation for faulty products as Elektroimportøren does not currently request compensation for these products and the customer is asked to dispose of the product. We do not however know if there are incentives in place for Elektroimportøren to cover the cost of the faulty products with a sales value below 200 NOK that are produced by an external manufacturer. One example of an agreement could be that the supplier covers a part of the cost instead of Elektroimportøren covering everything.

Another option for reducing the cost of complaints could be to look at return avoidance presented in 2.1.3.1, which discusses the quality of the product. Elektroimportøren could look at historical data to see certain products that receive a larger volume of complaints and take into consideration switching out the product or the supplier with someone providing a higher quality.

## **6.2 Interpreting the business process model and the costs occurring for returns**

Looking at the returns process, we first encounter some administrative costs as the customer contacts Elektroimportøren and they must decide if the customer is eligible for a product return. If they are the first cost is generated in step 41 as transport cost from the customer and to Elektroimportøren. In step 43 and 44 we identified handling costs for collection and inspection/sorting which currently is not calculated as they currently have excess capacity available for handling it. There are four different options when determining the condition of the product in step 45. If the product is as good-as-new it goes through to step 46, which activates step 47 and 48 at the same time. The customer is refunded their purchase in step 47 and Elektroimportøren puts the product back into the normal inventory in step 48. If the product is used and thus considered a second-hand product, it goes through to step 51. Step 51 activates steps 52 and 53 at the same time. Step 52 refunds the customer their purchase while step 53 registers the product in their second-hand inventory. Step 54 follows after the product is registered where it is then transported to their warehouse outlet that sells their second-hand products. If the product is damaged it goes through to step 57. This activates step 58 and 59 at the same time. Step 58 either refunds the customer their purchase or replaces the damaged product with a new one. Step 59 disposes of the product. The last option is picking-error, which is step 62, this activates step 63 and 64 at the same time. Step 63 sends a new product to the customer, while step 64 registers the wrongly picked product back into inventory.

We identified a key cost driver for the returned products to be the return transportation cost in step 41, as Elektroimportøren offers free returns. We also identified a key cost driver in step 54 where the second-hand product has been transported to the warehouse to be sold as second hand goods. We see in table 7 that by reducing the retail price for the product, they miss almost 1.5 million NOK in profit. We also identified warehousing costs as a cost driver for the second-hand products in table 8 showing the increasing warehousing costs as Elektroimportøren experiences increase in their return volumes. The warehousing costs shows the cost if the product is sold within a month.

Looking at figure 5, 6 and 7 we see the growing trend of higher return volumes, which makes sense with the research that shows a growing trend of online purchasing (Bring Research 2017), (Stock, Speh og Shear 2006). Looking at the costs presented here, Elektroimportøren should be prepared to see a continued growth, which will also increase the capacity level needed to handle the products. As it currently stands Elektroimportøren have excess capacity to handle the return products without investing in increased capacity, but as we can see from the forecast this trend will increase in the future and more capacity will be needed to handle all the returns. If we look at table 9, we see the forecasted return value in February 2018 to be over 1.3 million NOK returned, compared to February 2017 which had a total return of 322 067 NOK. This is a 317.5 percent increase. The forecast is calculated using a 95 percent confidence interval level as we found it accurate enough to account for the sample size used. Looking at December 2018, it is forecasted an increase of 813 841 NOK of returned sales value, making the total forecasted at the end of year 2018 to be 1 993 045 NOK. With this increase in returns, we find it reasonable to assume that it will result in more products having to be sold as second-hand, leading to further profit loss and a higher transportation cost for Elektroimportøren. More returned products would also drive up the cost of second-hand stock.

We present several options for reducing returns in our theoretical framework. For return management this is specified in section 2.1.3.1 Return Avoidance. This could include training of warehouse staff, making sure routines are in place to make sure the correct product is sent to the customer and thus reducing picking error. A different type of return avoidance could also be the training of customer service agents so when customers reach out to receive pre-sale help, the agents talking to them have the needed expertise to guide their purchase, resulting in fewer customers buying the wrong product. This could also be expanded to the website. Several successful online companies provide their customer with user guides and instructional videos on how to choose the correct product based on their need and how to properly use it. There is also an option to include user comments on the website so the customer can see the feedback the product received from previous customer, potentially guiding the customer to the product that suits his need the best. An important factor in avoidance is providing the customer with as much knowledge pre-sale as possible, helping the customer make a qualified choice to improve the chance of a successful first purchase. There is a significant lower amount of returns in traditional retail

outlets compared to online stores, which is often the result of the customer being guided by qualified sales personnel to choose the correct product suiting their needs.

Successful gatekeeping can reduce the product volume entering the reverse flow of goods. Successful gatekeeping is often the result of investment into personnel competency and standardized operation procedures that gives new and existing personnel thorough information on the current return policy. Gatekeeping can also be used when a customer contacts Elektroimportøren to start the return process. In some cases, the customer may have the right product, but not the knowledge on how to use it. Having qualified personnel communicate with the customer can potentially reduce returns as they guide the customer on how to use the product properly.

### **6.3 Potential actions to increase return management efficiency**

There are several things Elektroimportøren can do to improve their return management process to enhance profitability, improve revenue and reduce costs. Since there is no dedicated personnel to handle the product returns at Elektroimportøren it could be beneficial to hire a third-party logistics provider, because product return management requires more than part time effort and minimal resources. Through discussions with Elektroimportøren, we uncovered that one of the reason they wanted us to look at return logistics, is because they have little to no track over the current return situation and were looking to gain some insight on this process and how to efficiently manage it. They could therefore contact companies which are specialized in return management and can benefit from their expertise and efficiency.

We experienced difficulties with noise in the data set and a solution for Elektroimportøren to get a more accurate view of their return processes could be to implement an information system to track their return orders. This could improve the probability of correct registration and data entry of the return products and could be used to see valuable information on return patterns, which provides information about the buying habits and expectations of the customer. Research also shows that the faster a company is able to process a returned item, the more likely it is for a company to benefit economically from disposition activities (Stock, Speh og Shear 2006).



## **7 Conclusion, limitations and further research**

This chapter concludes the research done in our thesis, discuss our limitations and suggests further research.

### **7.1 Conclusion**

The research done in our thesis aims to map the business process of Elektroimportørens product returns and identify the costs associated with these processes. The researcher identified the business process model with the steps using both product returns and product complaints and the different paths these processes can take depending on the manufacturer of the product, the price of the product and what state the product is returned in. We identified several key cost drivers associated with this business process for both product returns and complaints, such as the loss of value in the product, the loss of profit, transportation and warehousing. We were also able to look at historic return data, which highlighted the growing trend of product returns and using this we were able to forecast the expected product return for Elektroimportøren. This allowed us to come up with suggestions based on our theoretical framework on how Elektroimportøren can work to reduce their total return volumes and costs. We found this research to be very important, as there has previously not been any research on identifying the costs of allowing product returns, to the best of our knowledge. Identifying these costs and the growing trend of product returns could be important for companies such as Elektroimportøren in order for them to manage it and sustain a competitive advantage.

### **7.2 Limitations**

Limitations to our thesis includes the scope we used for our research. We conducted a case study on a specific company, Elektroimportøren, which has a special position in its market as both a retail and wholesaler. We are therefore aware that the results found here might not be applicable for every other company operating with an online store.

There has been no previous research on identifying the real cost of allowing product returns and we were therefore unable to compare our results with previous research. We experienced difficulties with the data set retrieved from Elektroimportøren as we found a lot of noise in the data. The secondary data we received are therefore not as accurate as we would have preferred it to be.

We were unable to model the cost of the return process time due to Elektroimportøren lacking information on their process times.

We wished to look at the rate of returning customers that previously returned products to Elektroimportøren to see if their return policy affected customers relationship negatively or positively. We were unable to acquire this information as Elektroimportøren did not save this type of data due to strict privacy laws in Norway.

### **7.3 Further research**

For further research, we would recommend further investigation into a wider range of companies within the e-commerce business. We would also find it interesting to look at what gains a company benefits from by allowing their customers a generous return policy compared to a strict return policy. This could include how much more a company must sell in order to make up for the loss of allowing returns.

It would also be interesting to see what value recapturing a company can benefit from by utilizing a more efficient disposition process for their returned complaint products.

The business process model for Elektroimportøren return process could be used in other study to compare and evaluate the return processes of other companies.

## References

- Anagnostopoulos, Christos. 2017. *On Qualitative Research: Seminar for MSc in Logistics*. Molde, September 25.
- Arlbjørn, J. S, and Á. Halldórsson. 2002. "Logistics knowledge creation: reflections on content, context and processes." *International journal of physical distribution & logistics management*, Vol. 31, Issue: 1 22-40.
- Blumberg, Donald F. 1999. "Strategic Examination of Reverse Logistics & Repair Service Requirements, Needs, Market Size, and Opportunities." *Journal of Business Logistics*, Vol. 20, Issue: 2 141-159.
- Bonev, Martin. 2012. *Managing reverse logistics using system dynamics: A generic end-to-end approach*. Hamburg, DEU: Diplomica Verlag.
- Bring Research. 2017. *Bedre kundeinnsikt gir økt salg: Slik lykkes du med levering og retur*. Semi formal, Bring Research.
- Cojocariu, Cezar Radu. 2013. "The Reverse Gear of Logistics." *Revista De Management Comparat International*, Vol. 14, Issue: 1 153-164.
- de Brito, Marisa P., and Rommert Dekker. 2003. "A Framework for Reverse Logistics." *St. Louis: Federal Reserve Bank of St Louis*. 1-29.
- de Brito, Marisa. P., and Rommert Dekker. 2002. "Reverse Logistics - a Framework." *St. Louis: Federal Reserve Bank of St Louis*.
- Elektroimportøren. 2017. *Elektroimportøren.no*. Accessed April 30, 2018.  
<https://www.elektroimportoren.no/infosenter/infosenter/Document.html>.
- Ellram, Lisa M. 1996. "The use of the case study method in logistics research." *Journal of Business Logistics*, Vol. 17, Issue: 2 93-138.
- Erol, Ismail, Meltem Nurtanis Velioglu, Funda Sivrikaya Serifoglu, Gülçin Büyükközkán, Necati Aras, Nigar Demircan Çakar, and Aybek Korugan. 2010. "Exploring reverse supply chain management." *Supply Chain Management; Bradford*, Vol. 15, Issue: 1 43-54.
- European Commission. 2016. *European Commission*. June 9. Accessed May 1, 2018.  
[http://ec.europa.eu/environment/waste/weee/legis\\_en.htm](http://ec.europa.eu/environment/waste/weee/legis_en.htm).

- Fleischmann, Mortiz, Hans Ronald Krikke, Rommert Dekker, and Simme Douwe P. Flapper. 2000. "A characterisation of logistics networks for product recovery." *Omega*, Vol. 28, Issue: 2 653-666.
- Guba, Egon G. 1981. "Criteria for Assessing the Trustworthiness of Naturalistic Inquiries." *Educational Communication and Technology*, Vol. 29, Issue: 2 75-91.
- Gupta, Surendra M. 2013. *Reverse Supply Chains: Issues and Analysis*. U.S.: CRC Press.
- Johnson, R. Burke, and Anthony J. Onwuegbuzie. 2004. "Mixed methods research: a research paradigm whose time has come." *Educational Researcher*, Vol. 33, Issue: 7 14-26.
- Kovács, Gyöngyi, and Karen M. Spens. 2005. "Abductive reasoning in logistics research." *International Journal of Physical Distribution & Logistics Management*, Vol. 35, Issue: 2 132-144.
- Lambert, Douglas M. 1975. *The development of an inventory costing methodology: A study of the cost associated with holding inventory*. Chicago: National Council of Physical Distribution Management.
- Lambert, Douglas M. 2004. "The eight essential supply chain management processes." *Supply Chain Management Review*, Vol. 8, Issue: 6 18-26.
- Lambert, Douglas M., and James R. Stock. 1982. *Strategic Physical Distribution Management*. Homewood, Ill: Irwin.
- Lee, C. K. M., and Jasmine Siu Lee Lam. 2012. "Managing reverse logistics to enhance sustainability of industrial marketing." *Industrial Marketing Management*, Vol. 41, Issue 4 589-598.
- Lovdata. 2014. *Lovdata*. June 20. Accessed April 30, 2018. <https://lovdata.no/dokument/NL/lov/2014-06-20-27>.
- Mafakheri, Fereshteh, and Fuzhan Nasiri. 2013. "Revenue sharing coordination in reverse logistics." *Journal of Cleaner Production*, Vol. 59 185-196.
- Mukhopadhyay, Samar K., and Robert Setoputro. 2004. "Reverse logistics in e-business: Optimal price and return policy." *International journal of physical distribution & logistics management*, Vol. 34, Issue: 1 70-88.
- Murphy, P. R., and R. F. Poist. 1988. "Management of logistical retromovements: An Empirical analysis of literature suggestions." *Journal of the Transportation Research Forum* 177-184.
- Nairn, Geoff. 2003. "Not Many Happy Returns: UNWANTED GOODS by Geoffrey Nairn: Reverse Logistics Causes Headaches and Eats into Already Thin Margins."

- Financial Times*, February 05: 1-4.  
<https://search.proquest.com/docview/249373868?accountid=40814>.
- Pinkerton, I. 1997. "Getting religion about returns." *Dealerscope Consumer Electronics Marketplace*, Vol. 39, Issue: 11 19-20.
- Ravi, V., and Ravi Shankar. 2005. "Analysis of interactions among the barriers of reverse logistics." *Technological Forecasting and Social Change*, Vol. 72, Issue: 8 1011-1029.
- Richey, R. Glenn, Haozhe Chen, Stefan E. Genchev, and Patricia J. Daugherty. 2005. "Developing effective reverse logistics programs." *Industrial Marketing Management*, Vol. 34, Issue 8 830-840.
- Rodwell, M. K., and K. V. Byers. 1997. "Auditing constructive inquiry: Perspectives of two stakeholders." *Qualitative Inquiry*, Vol. 3, Issue: 1 116-134.
- Rogers, Dale S., and Ronald S. Tibben-Lembke. 1998. *Going Backwards: Reverse Logistics Trends and Practices*. University of Nevada, Reno: Reverse Logistics Executive Council.
- Rogers, Dale S., and Ronald Tibben-Lembke. 2001. "An examination of reverse logistics practices." *Journal of Business Logistics*, Vol. 22, Issue: 2 129-148.
- Rogers, Dale S., Douglas M. Lambert, Keely L. Croxton, and Sebastián J. García-Dastugue. 2002. "The Returns Management Process." *The International Journal of Logistics Management*, Vol. 13, Issue: 2 1-18.
- Rogers, Dale S., Ron Lembke, and John Bernardino. 2013. "Reverse logistics: A New Core Competency." *Supply Chain Management Review*, Vol. 17, Issue: 3 40-47.
- Sachdeva, J. K. 2008. *Business Research Methodology*. Mumbai: HIMALAYA PUBLISHING HOUSE PVT. LTD.,.
- Saunders, Mark, Philip Lewis, and Adrian Thornhill. 2009. *Research Methods for Business Students*. Pearson Education.
- Schatteman, Olaf. 2003. "Reverse Logistics." In *Gower handbook of supply chain management*, by John Gattorna, Robert Ogulin and Mark W. Reynolds, 267-279. Aldershot: Gower.
- Shenton, Andrew K. 2004. "Strategies for Ensuring Trustworthiness in Qualitative Research Projects." *Education for Information*, Vol. 22, Issue: 2 63-75.
- Stock, James R. 1998. *Development and Implementation of Reverse Logistics Programs*. Council of Logistics Management.

- Stock, James R., and Douglas M. Lambert. 2001. *Strategic logistics management*. New York: McGraw-Hill Companies, Inc.
- Stock, James, Thomas Speh, and Herbert Shear. 2006. "Managing product returns for competitive advantage." *MIT Sloan Management Review*, Vol. 48, Issue: 1 57-62.
- Thierry, Martijn, Marc Salomon, Jo Van Nunen, and Luk Van Wassenhove. 1995. "Strategic issues in product recovery management." *California Management Review*, Vol. 37, Issue 2 114-135.
- Trager, L. 2000. "Not so many happy returns." *Interactive Week*, Vol. 7, Issue: 11 44-45.
- Waters, Donald. 2009. *Supply chain management : an introduction to logistics*. Hampshire: Palgrave Macmillan.
- Woodside, Arch G. 2010. *Case study research : theory, methods, practice*. Bingley: Emerald Group Publishing Limited.
- Yin, Robert K. 2009. *Case study research : design and methods*. SAGE.